

# A STUDY OF CHARGE STRATIFICATION IN THE TWO-STROKE ENGINE WITH GASOLINE INJECTION

## ИССЛЕДОВАНИЕ ПОСЛОЙНОГО СМЕСЕОБРАЗОВАНИЯ В ДВУХТАКТНОМ ДВИГАТЕЛЕ С ВПРЫСКОМ БЕНЗИНА

Assoc. Prof. Eng Karasev V. PhD, Assoc. Prof. Eng Sokolov I. PhD, Eng Kuklin V., Eng Kulikov R., Eng Khapskiy A.  
Russian Federal State Budgetary Educational Institution of Higher Professional Education "Kostroma State Agricultural Academy",  
Kostroma city, Russian Federation

**Abstract:** *Charge stratification of the combustible mixture through separate input of air and gasoline in the two-stroke gasoline engine is studied. Clean air enters the upper part of the vent channels through the check valve plate and then goes into the crank camera. The mixing occurs in the crank chamber and is controlled by the time and duration of the fuel injection nozzle. Before blowing cylinder volumes of the purge channels are filled mostly with clean air. The volume of the crank chamber is filled with a mixture of gasoline and air. Blowing the working volume of the cylinder is carried out mostly by clean air volumes from the purge channels. The process of purging is completed by filling the cylinder with fresh mixture from the crank chamber. Layer-by-layer purging of the cylinder greatly reduces the direct losses of fuel into the exhaust system. This leads to increased fuel efficiency of the two-stroke engine and reduces environmental pollution. Maximum power is achieved for mixtures with air ratio  $\alpha = 1.0$ , the best efficiency on the poorer mixtures with  $\alpha = 1,2-1,25$ . In this case the reduction of fuel consumption is up to 20 %.*

**KEYWORDS:** TWO-STROKE ENGINE, GASOLINE INJECTION, CHARGE STRATIFICATION, SCAVENGING OF THE CYLINDER, AIR RATIO.

### 1. Introduction

Internal combustion engines running on gasoline, are currently the main source of energy for vehicles, various types of agricultural machinery, motorcycles and many other types of equipment.

The foundation of any engine using hydrocarbon fuels, is the process of converting thermal energy of the fuel during its combustion into mechanical work. In most engines this process is carried out on the four-stroke cycle, but only one measure - the third - is working. For the other cycles the input of mechanical energy for compression of the combustible mixture and the gas exchange in the cylinder is required. Therefore, the vast majority of four-stroke engines have four or more cylinders. The engines provide high power per unit working volume of the cylinder, a fairly good economy, affecting fuel consumption and low exhaust emissions, which reduce the means of neutralization.

However, many types of small vehicles - motorcycles, compact tractors, motor grass-mowing machines, snowmobiles, small boats and other types - use the energy source of one - and two-cylinder engines operating on the two stroke cycle. The main advantage of the two-stroke cycle is higher liter capacity because the stroke in such engines occurs twice as often in comparison to the four-stroke ones for the same frequency of rotation of the crankshaft. The lack of valve gear determines the ease of construction and maintenance of the engine, as well as small dimensions. But the main disadvantages of these engines, limiting their widespread distribution, are low efficiency of their work and higher emissions. To address this problem the present study is aimed.

### 2. Prerequisites and means for solving the problems.

The principal difference between the two-stroke engines and the four-stroke ones is the lack of intake and exhaust valves. Gas exchange in the cylinder is carried out through the intake, exhaust and inlet ports located on the surface of the cylinder. For the process of gas exchange the volume of the crank chamber, which is filled with a mixture of gasoline and air through the inlet port when the engine works, is also used. The processes of exhausting through the outlet port and filling the cylinder with a fresh mixture from the crank chamber via the scavenging ports occur simultaneously. With the high gas exchange a portion of the fuel gets into the exhaust system and further into the atmosphere, which explains the high

fuel consumption and high emissions. If you consider that the main modes of two-stroke gasoline engine run rich mixtures with excess air ratio  $\alpha = 0.7$  to 0.9, the loss of fuel due to this are even greater.

The most effective way of solving this problem is the use of direct injection of gasoline with electronic control that allows you to bring the performance of two-stroke engines in terms of efficiency and toxicity closer to four-stroke ones [1, 2].

But direct injection leads to significant complexity of the design and increases the cost of the engine, which is unacceptable for engines intended for light motor cycles and also small machines. The most promising is the improvement of the two-stroke engine with the crank chamber scavenging, providing substantial or complete exclusion of the direct loss of fuel by blowing. In this case, there is one of the main advantages of these engines - simple design.

One of the recognized and effective ways to substantially reduce the loss of fuel in the exhaust system in the two-stroke engine is the stratification of the fuel-air charge in the intake and gas exchange [3, 4].

### 3. The problem solution

Our research is aimed at improving the two-stroke gasoline engine, which is implemented by the layer-by-layer mixing processes due to separate admission of air and gas at inlet and purge.

At the first stage of work, when we used the carburetor for mixing air and gasoline, we investigated the scheme of the stratified mixture formation, shown in (Fig. 1,a). Fuel 1 is mixed with the air 2 in the lower chamber of the carburetor and enriched air-fuel mixture 7 fills the crank chamber. In addition, the air through the upper chamber of the carburetor, a lateral recess in the bottom of the recess of the piston 3 at the same time fills the volume of purge channels. By the end of the inlet when the piston is at TDC, the volume of purge channels is filled with clean air, and the subpiston space and the crank chamber are filled with enriched mixture.

With the motion of the piston down to BDC (Fig. 1,b) compression of stratified charge occurs. After opening of the exhaust port, the exhaust gases 4 rush into the exhaust system. Since the opening of the inlet ports the displacement of the exhaust gas is carried out by a flow of clean air 5 and poorer mixture 6. At the final stage of the purge the cylinder is filled with a rich mixture 7 from the crank chamber.

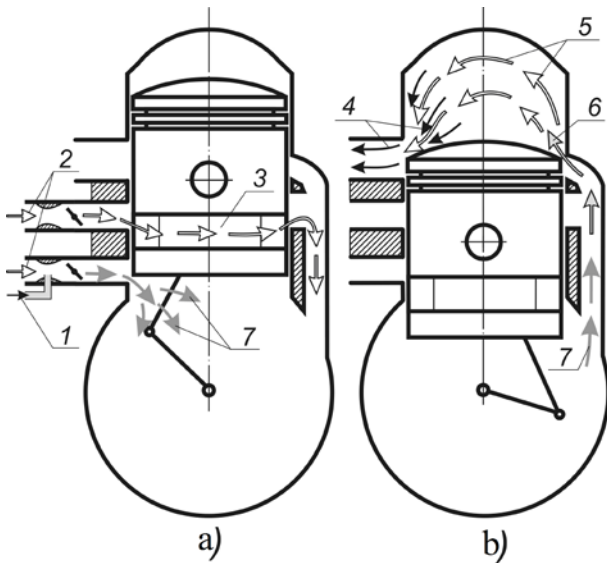

Fig. 1. Diagram of layered entering fresh charge:  
 1 – admission fuel; 2 – admission air; 3 – the recess in the piston;  
 4 – exhaust gases; 5 – clean air;  
 6 – poorer mixture; 7 – rich mixture

By physical modeling of the process of mixture formation with application of the "tracer" gas CO<sub>2</sub> instead of fuel we estimated the distribution of mixture in the purge volume of channels on the excess air ratio in the local points of each channel. The results of the experiments (Fig. 2) confirm the significant stratification of the fresh charge by the beginning of the purge.

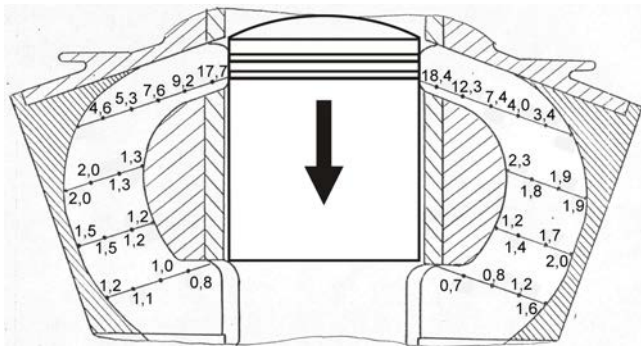

Fig. 2. The stratification of the mixture in the venting channels:  
 0,8; 1,2; 5,3 etc.– the excess air ratio  
 at the local point of the scavenging channel

At the top of the channels adjacent to the vent windows the poorer mixture with  $\alpha = 12-18$  units is concentrated. The middle part of the channel is filled with a poor mix with  $\alpha = 2,0-2,3$ . In the lower part of the channel mix is also poor with  $\alpha = 1,2$  to 1,5. And only at certain points of the portion of the channel immediately adjacent to the crank chamber, the mixture is somewhat enriched.

The data obtained in the first stage of this work allowed for us to make a conclusion about the prospects of this direction of improving the two-stroke engine and proceed to the second stage.

At this stage, the study of the efficiency of the stratification of the fuel-air charge in two-stroke engine continues with the use of phased fuel injection using electromagnetic injectors. In this study we look at two different schemes of engine operation with a stratified mixture formation and injection.

One of the schemes of the two-stroke engine with a bundle of fresh charge is characterized by the presence of cumulative chambers 1, electromagnetic injectors 2 and window 4 in the piston (Fig.3).

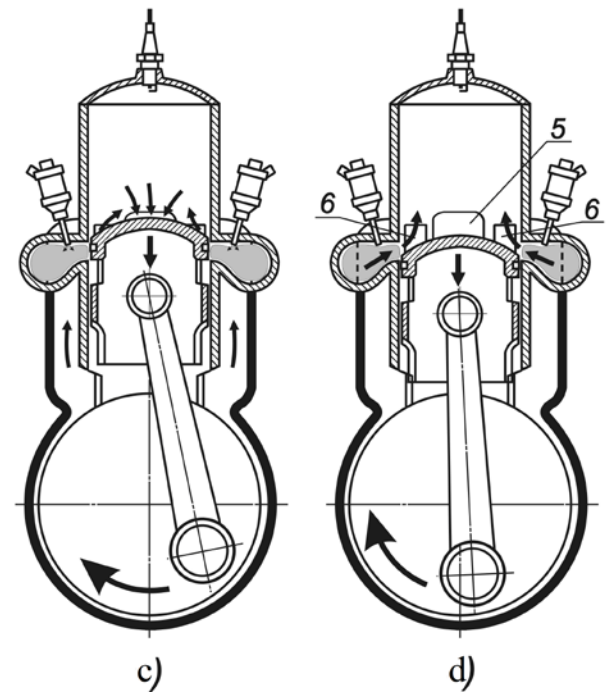
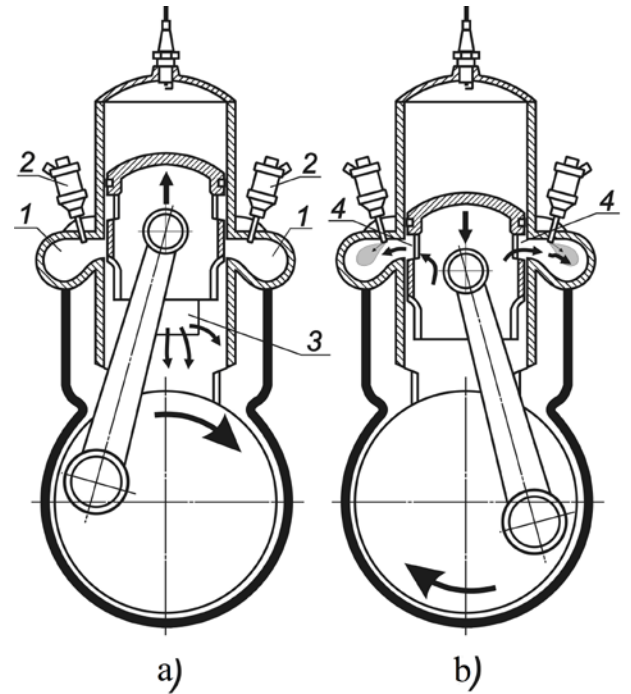

Fig. 3. The scheme of work of the engine with the stratification of the fresh charge and the cumulative chambers:  
 1 – cumulative chambers; 2 – electromagnetic nozzles;  
 3 – the inlet port clean air; 4 – ports in piston;  
 5 – the outlet port; 6 – vent windows

The cumulative chambers are filled with clean air with the simultaneous injection of the volume of gasoline from the two electromagnetic nozzles, which leads to the formation of the enriched fuel-air mixture in the cells in the process of gas exchange. Purging is carried out with clean air, and at the time it is completed the air-fuel mixture is supplied to the cylinder from the cumulative chambers.

The diagram of the engine is shown in (Fig. 3). When the piston moves up, the clean air fills the crank chamber through the open inlet port 3. At the same time the fuel-air mixture compresses above the piston (Fig. 3,a). At the end of the compression, the electric spark ignites the mixture and the piston moves down during

the power stroke and it closes the inlet port and compresses the air in the crank chamber, and the window in the piston opens the inlet to the chamber and pre-compressed air is supplied (Fig. 3,b). At the time of the opening of the inlet the fuel supply is started by the electromagnetic injectors 2. The further downward movement of the piston closes the inlet openings of the cumulative cameras, opens the outlet port 5, and then the scavenging ports 6. Graduation occurs, purging and filling the cylinder with clean air (Fig. 3,c). If necessary, the fuel supply may continue until the opening of the piston upper edges of the cell Windows. At the time of completion of the purge enriched mixture from the shaped chambers under pressure exceeding the pressure in the cylinder, rapidly fills the cylinder (Fig. 3,d). Thus, the cleaning of the cylinder from the exhaust gas is carried out by clean air, but at the end the gas cylinder is filled with the enriched air-fuel mixture that, when mixed with clean air, forms a working air mixture suitable for combustion. With proper selection of the geometric shape and dimensions of the shaped chambers, as well as the geometry of the connecting channels between the chambers and the cylinder of the engine, it is possible to significantly reduce the loss of fuel into the exhaust system by blowing.

The proposed scheme of gas exchange with the use of cumulative cameras was implemented on the experimental engine (Fig. 4), which shows the placement of electromagnetic injectors in jet chambers.



Fig. 4. Two-stroke engine with stratified mixture formation and the cumulative chambers:

- 1 – pressure-sensitive detector; 2 – injector rail;  
3 – electromagnetic nozzles;

Preliminary results of the bench tests confirmed the efficiency of the proposed scheme of gas exchange and experimental design of the engine.

In another diagram (Fig. 5) a supply of clean air in the crank chamber 8 is carried out via the purge channels 2 connected to the outside of the cylinder with two air inlet channels in its upper part 1. In the cylinder there is no inlet mixing box.

The process of mixing is carried out in the crank chamber 8 of the fuel supply via the electromagnetic nozzles 5 and is governed by the time and duration of injection.

At the inlet (Fig. 5,a), when the piston 6 moves upwards, since the closing of the cylinder inlet ports 7 in the crank chamber 8 creates a negative pressure transmitted through the purge 2 channels in the intake air channel 1. The air from the atmosphere rushes into the general air channel 4, through the throttle valve and the 3 in the air conduit 1 and through the purge 2 channels fills the crank chamber 8.

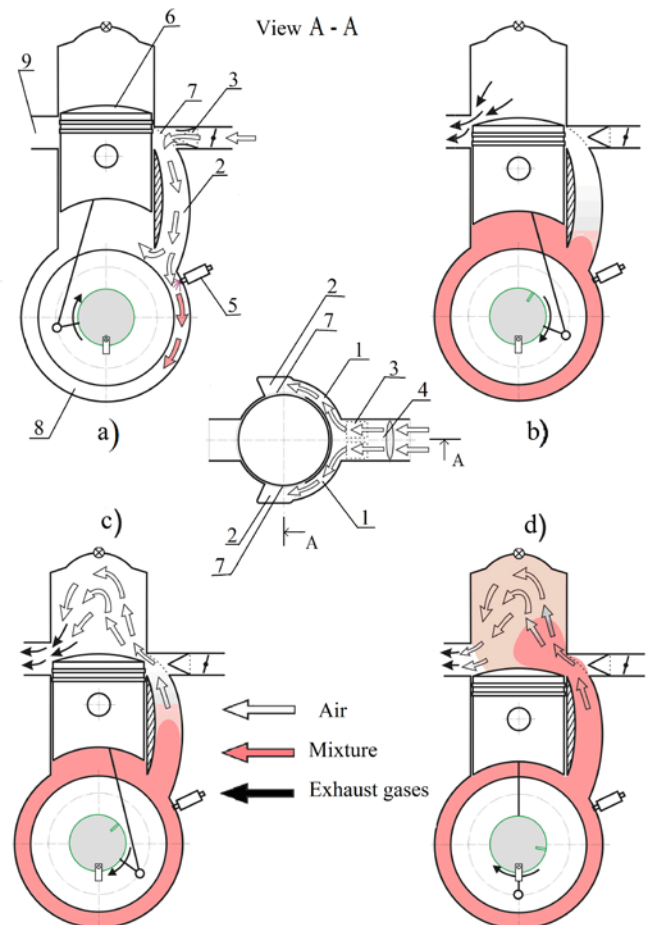

Fig. 5. The scheme of the layer-by-layer mixing and venting in the two-stroke engine with fuel injection:

- 1 – air intake channels; 2 – the purge channels;  
3 – return plate valve; 4 – air channel;  
5 – nozzle; 6 – piston; 7 – admission port;  
8 – crankcase; 9 – exhaust port

When the piston moves down (Fig. 5,b) the crank chamber is pressurized, which locks the reverse valve plate 3. At the beginning of the purge (Fig. 5,c), after opening of the inlet ports 7, the displacement of the exhaust gas from the cylinder is carried out by a flow of clean air from the purge channel 2 to the outlet port 9. When the piston moves closer to the bottom dead point, the fuel injected by the injector 5 in the crank chamber 8 is mixed with the purge air and coming through the purge 2 channels into the cylinder, it completes the process of purging (Fig. 5,d). Purging is carried out mostly by clean air, which significantly reduces the direct loss of fuel. This leads to the increased fuel efficiency of the two-stroke engine and reduces environmental pollution. To assess the stratification of the mixture at the inlet and purge the physical modeling of stratified mixture formation is conducted (Fig. 6). In this case, the nozzle emits carbon dioxide instead of gasoline.

Special gas samplers perform stroboscopic sampling of the gas-air mixture from the crank chamber, from different points of the volumes of purge channels and the combustion chamber. Gas analysis of the samples allows to determine the percentage of carbon dioxide in the mixture with air and translate this content calculated by the nomograph in the excess air ratio  $\alpha$ . Thus the distribution and qualitative composition of the mixture by gas exchange is determined and is estimated to reduce the losses of fuel into the exhaust system by blowing.



Fig. 6. Two-stroke engine with stratified mixture formation and injection gasoline

- 1 – air intake channels; 2 – the purge channels;  
3 – return plate valve; 4 – throttle;  
5 – nozzle; 6 – connecting pipe gas sampler;

#### 4. Results and discussion

Bench testing of the two-stroke engine with a carburetor to mix fuel and air shows high efficiency of the stratified mixture formation. The stratification of the fresh charge intake has a positive effect on engine performance parameters and reduction of the toxicity of exhaust gases (Fig 7.). In the stratified mixture formation in an economical and power state the total composition of the mixture at the inlet is more depleted compared with the conventional scheme of gas exchange. The difference is 0.15 to 0.20 units on the excess air ratio. In this way, the efficiency is improved by 10-15%. The engine in the power mode is accompanied by fuel economy by 15-20%.

This effect is mainly a confirmation of the fact that by blowing, the direct losses of fresh charge are the clean air and a portion of the lean mixture. The composition of the combustion mixture in the cylinder is more enriched than the calculated one at the intake by the expenditure of fuel and air. Therefore, the maximum power and lowest fuel consumption in the engine with stratified mixture formation are achieved with leaner mixtures.

Reduction in the direct losses of the fuel mixture by blowing is reflected in the reduction of emissions of unburned hydrocarbons CH from the exhaust gases by 25-30%. The content of carbon monoxide CO on the power mode is reduced by 1.5 times. The indexing of the experienced engine showed the best stability of the workflow, assessed by the degree of irregularity of cycles  $\delta$ , the value of which at the economical mode is 5-6%, while the production engine irregularity amounts to 12-13%, ceteris paribus.

Thus, layer-by-layer mixing in the two-stroke gasoline engines is an effective way to improve performance of their work.

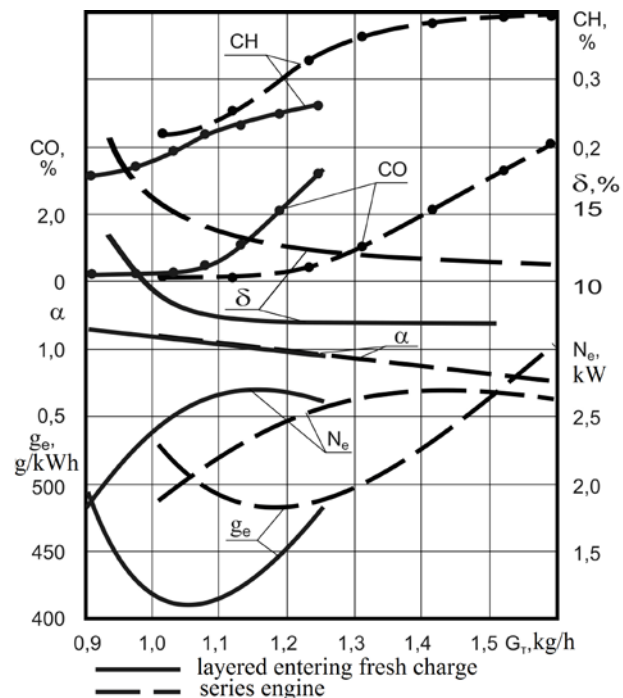

Fig 7. The characteristic of the fuel supply:  
 $n=3400 \text{ min}^{-1}$ ,  $\varphi_0=0,40$

#### 5. Conclusion

The main direction of improvement of the two-stroke gasoline engines is a significant reduction in direct losses of fuel during scavenging. The rapid development of modern electronic system fuel injection allows you to create different schemes of work for the two-stroke engine with stratified mixture formation, in which the scavenging is carried out with clean air. The efficiency of such engines by the values of fuel consumption approaches the efficiency of the widespread four-stroke engines. This retains the main advantages of the two-stroke engines - simple design, high power density, small size.

#### 6. Literature

1. Патент RU 2344299 МПК F02B57/04 F02B23/00 Двухтактный бензиновый двигатель с непосредственным впрыском топлива и электронной системой управления. Авторы Мысляев В.М., Максакова И.В., Ахметов Д.Н. заявл. 29.06.2007; опубл. 20.01.2009, Бюл. N 2.
2. Патент RU 2038493 МПК F02B25/20 Двигатель внутреннего сгорания. Авторы Дьяченко В.Г., Мотлохов А. В., Амосов С.В., Владимирский А.И., Молчанов П.Н., Савинов О.И., Гришин И.Я., Гоцкало Б.Л.
3. Куликов Р.Н., Карасев В.А. Обоснование моделирования углекислым газом послонного смесеобразования в двухтактном двигателе. Сборник статей 66 международной научно-практической конференции в трех томах «Актуальные проблемы науки в агропромышленном комплексе». Т2.- Караваево:2015-с.118-121.
4. Патент RU 2466281 МПК F02B25/22 F02B25/16 Двухтактный двигатель с послонной продувкой. Владелец патента: МАКИТА КОРПОРЕЙШН (JP) Автор Такаянаги Йосиаки (JP)