

DESIGN AND BULID VEHICLE WITH SOLAR DRIVE FOR WORLD SOLAR CHALLENGE COMPETITION

Eng. Madziara S.¹, Eng. Najbert S.¹, Ph.D. Eng. Wozniak M.¹, Ph.D. Eng. Kubiak P.¹, Prof. M.Sc. Ozuna G.², Ph.D. Eng. De La Fuente P.³, M.Sc. Eng. Jozwiak P.¹

Department of Vehicles and Fundamentals of Machine Design – Lodz University of Technology, Poland

Department of Industrial Engineering and Systems - University of Sonora, Mexico²

Department of Fluid-Energy Machines - Ruhr-University Bochum, Germany³

171243@edu.p.lodz.pl, 174616@edu.p.lodz.pl, marek.wozniak.1@p.lodz.pl, przemyslaw.kubiak@p.lodz.pl, gozuna@industrial.uson.mx, pablo.delafuente@rub.de, jozwiak.piotr@gazeta.pl

Abstract: The paper shows problems and examples finishes solutions applied in the motor industry which be used by solar car production to competition World Solar Challenge. The subject matter will contains the mechanical matters connected with endurance of materials, the wheel set and aerodynamics as well as the electric questions relating the photovoltaic and conversion of electric energy on mechanical energy.

Keywords: SOLAR, MOTION RESISTANCE, COEFFICIENT, CHASSIS, VEHICLE.

1. Introduction

Request for energy grows with development of civilization. Prognoses' provide that about 2050 year to the reserves of petroleum are exhaust. The continuous growth of prices of fuels is consequence of this. Environmental considerations was aimed to decrease of consumption of conventional fuels also. Therefore it conducts on the world policy having on aim the development of alternate sources of energy. The sunny radiance is one from renewable natural resources forms of energy. Except the new sources of energy were look for higher efficiency of devices and the most effective utilization of energy. The international competition World Solar Challenge is one of helping such development initiatives.

The participants of competition be divided on 4 class: Challenger, Cruiser, Adventure and Evolution. The students from Scientific Wheel of Lovers of Motorization of Lodz University of Technology undertook the construction in Cruiser class with solar drive. The main aim of vehicles build in this category is design the innovative components which can be applied in mass production of motor industry. This marks that not efficiency but also functionality, safety and comfort depends

The machines constructors try to eliminate friction dry, replacing it more advantageous fluid friction. Because co-operating surfaces are not ideally smooth, on the top of irregularity of surface could be condition of dry or boundary friction and cavities are fill by lubricant. In such conditions the friction in the rough contact surfaces is the mixed friction.

2. The power gained from solar panels

The optimal angle of inclination of solar panels mounted on the vehicle was choosing by program written of the incidence analyzing angle on rout of competition (3000[km] from Darwin to Adelaide). Road by Australia in large part leads in south direction, which marks that the sun in zenith will be under angle 65-85^o to level with northern direction, then for obtainment optimum power sunny panels should be the most horizontal. This be caused this, that in wounded hours and afternoon the sun shines properly from northern - east and northern - west. Therefore the use of panels oblique under angle 25^o driving in morning hours in directions south-eastern and on geographical width 24^oS (about half of rout) it would generate power about 24,8 [%] smaller than using the flat panels. It is this the essential information near constructing the figure of body. The current, which flows in circuit near conversion of sunny energy on electric we mark from equation:

$$I_{sl} = I_{sto} \left(\frac{S}{1000} \right) + J_0 \cdot (T - T_{odn}) \quad (1)$$

where: I_{sl} - Fault current for insolation [A], S - Power of solar radiation [W/m^2], T - Working temperature of cell [K],

T_{odn} - Fiducially temperature [298K], J_0 - Temperature coefficient [A/K].

The angle under which sunny radius fall down on cells in dependence from their inclination it is possible to assign from equation:

$$\begin{aligned} \cos \theta &= \sin \delta \sin \varphi \cos \beta - \sin \delta \cos \varphi \sin \beta \cos \gamma + \\ &+ \cos \delta \cos \varphi \cos \beta \cos \omega + \cos \delta \sin \varphi \sin \beta \cos \gamma \cos \omega + \\ &+ \cos \delta \sin \beta \sin \gamma \sin \omega \end{aligned} \quad (2)$$

where: γ - Azimuth of receiver, β - Inclination angle of cells, ω - hour angle, δ - sunny declination approximate by Cooper rule, θ - latitude.

$$\omega = 15 \cdot (\tau - 12) \quad (3)$$

$$\delta = 23,45 \cdot \sin \left(360 \cdot \frac{284+n}{365} \right) \quad (4)$$

where: τ - hour of the day, n - number of the considered day of year.

The next thing what would belong to take under attention is the fact of undistortable panels characterize with higher efficiency and the individual modules should be under equal angle the inclination of sunny rays. From preliminary analyses' appears that the panels about maximum surface provided for regulations of competition are able to generate the power of line 1,2 [kW].

3. Resistances

Resistances make up one of the most essential connected questions and this project with regard on limited and relatively small power which is possible to acquire from sunny panels. Maximum weight and capacity of the batteries is closely definite in regulations of competition.

In order to reduce the consumption of energy was aimed in cars to:

- Increase to efficiency of engine,
- Decrease vehicle weight,
- Decrease the motion of resistance of vehicle,
- Decrease the rolling resistance.

4.1. Aerodynamic resistance

Aerodynamic resistances make up the largest component near settled drive all resistances with constant speed therefore decrease their value is priority. The analysis of flows are carried out by finite

element method helps. Aerodynamic tunnel was designed in simulating program, for which Ahmeda and conditions shore mesh be made models on basis of investigations of real clod (Ahmed Bauds). The investigation of vehicle body is the next step. The assumption is obtainment the value of coefficient of resistance air (c_x) on level 0,15 for side face 2 m². The average city car example. the Kia the Cee'd get the coefficient of resistance of air on level 0,30 with side face on level 2,5 m², that means the constructed solar car will generate 40% less losses connected with resistance of air.

Necessary power to defeat the resistances of air was marked from equation:

$$P_a = c_x \frac{\rho v^2}{s} s \quad (5)$$

where: ρ – thickness of air, v - vehicle speed, c_x – side face of vehicle.

The next task connected with aerodynamics was obtained on front of construction the centers of high pressure and low on the end which possible autonomous flow of air was through cabin, which will assure the suitable ventilation for drivers without necessity the assembling of additional systems. This is essential from consideration on high temperatures current in Australia holding in period of competition and construction heating.

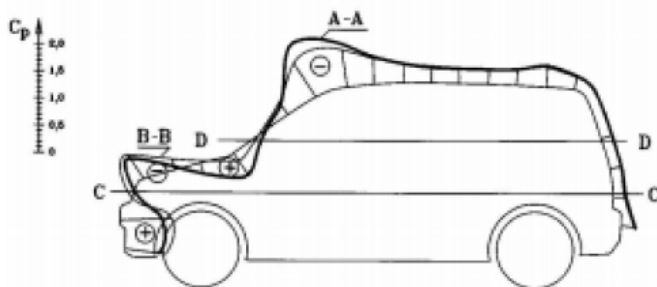

Fig. 1 Pressure distribution of body construction during vehicle movement.

5.2. Rolling resistance

The resistances of rolling first of all are connected and generated through tires losses. They be caused by hysteresis of springy deformation of coat tire, the friction and deformations of elements of tread in trace of contact point of tire with road, the adhesion of tread of surface, the losses of hitting of elements tread of road surface and losses of inertia formed on result surface the existence of "standing wave". The losses are negligible small taking under attention relatively small speed with which car will be driving. In reality about 90% losses comes into being on result of hysteresis of deformations. The state of roads in Australia are good but the terrains of tropical dry climate. The sand throwing by the wind on the road generates additional resistances included in calculation to connected with deformation of surface losses.

Radial relatively wide tires are producing the little losses (adapted to mass of car), from possibly large surface of contact point tire with surface of road, so to the angle the characterizing degree of bending the tread are so smallest. Pressure in tires should be the highest what should was consider during projecting suspension. The high temperature of environment near suitable doping of rubber mass causes the only fall of losses of hysteresis deformations. The also higher degree of waste of tire reduces the coefficient of resistance of rolling.

The aim will be use tires with coefficient of rolling on level = 0,0045-0,005. Good class tire has on level 0,01 this coefficient.

Transverse section such designed tire especially tire is approximate to rectangle for obtainment the maximally large

surface from surface of tire contact with road surface. This is slick type tire which able to decrease the friction with subsoil and loses caused by hitting blocks on the surface. The tire characterizes the endurance permitting on inflating her to 7,7 atm (for average car tire - 2,2 atm.).

The necessary power on defeat the resistance of rolling was marked:

$$P_T = (0,278) \cdot c_T \cdot \left[1 + \frac{v}{161}\right] \cdot G \cdot v \quad (6)$$

where: v – speed of vehicle, G – vehicle weight.

The resistance connected with rolling the vehicle come also from bearings and they are proportional to vehicle speed. To reduce it is possible by use of dear ceramic bearings. Losses connected with movement of power transmission system and the continuous recruitment of relatively large current, about 10%, through electric engine near generating the little powers. It is possible to reduce by cycle accelerating vehicle to set speed and the declutch the drive and switching off the engine. The characteristic of dependence of resistances after regard all resistances was got from velocity from which got the necessary power to the keep solid speed on level 65 km/h carries out about 1,5 kW. However car, with safety considerations and possibility efficient accelerating should dispose several higher power.

6. Construction of chassis

Suspension isolates influence of surface body for vehicles. The harmful influence of trembling's and vibration be eliminated on element of building of car, his endurance and time of exploitation. Moreover the aim of suspension is provide continuous contact tire from surface during usual drive and maneuvers connected from turning and turns round. Suspension also have considerable influence on safety directing and his concentrations.

Requirements for designed suspension for solar vehicle are:

- The mass of the solar vehicle the is considerably lower from average of size of car for everyday use. The car of mass about 400 kilograms aim of this project.
- The simplicity of suspension is the important element of the possibility easy repair.
- Elasticity, possibility of control and adapting for not only European surfaces, also Australian,
- The easiness of turn wheels in case of steered axis by steering system,
- The mass of only elements of suspension with this regard that every kilogram of additional mass causes the growth of motion resistances and it co growth of necessary energy for this goes on accelerating the vehicle
- The comfort and quality of driving and , keeping safety in turnings.

Suspension with double transverse control arms preform above mentioned requirements solution. Upper arm, bottom arm, spring and shock absorber in composition this type of suspension comes in. The control arms are fixed by ball joints with steering knuckle for front steering axis and by bearing hub for rear axis. The idea of independent suspension is important notion. The whole geometry of independent suspension with two control arms makes possible the realization of following requirements placed already in the kinematic-dynamic exact analysis.

- Placing on any required height the center of rotation,
- Use of geometry should make possible so called preventing the "diving" of car,
- Possibility of installing the stabilizer,
- It should limit the influence of inertia of mass body and strengths influencing across compensating him by vertical movement of set of suspension,

- Every of wheels makes possible independent amortized work on different kind roughness by drive is more stable,
- Operating with only geometry, mutual span of arms is possible to reduce in joints the appearing strengths and the fixing in body.

The basic foundation to see the full figure of suspension work is his behavior that all components and joints entering in his composition are stiff including the joints and elements of fixing. Adding this to already exchanged higher requirements possible the creation of dynamic scheme of considered suspension is. All the most important elements of suspension on scheme were contained.

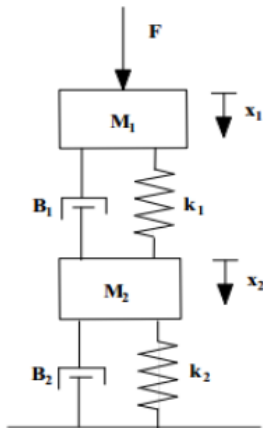

Fig. 2 Simplified model of shock absorbers working.

The springing mass is the weight of the vehicle influencing on the considered mechanism. Above mentioned scheme takes into account stepping out first of all on joints friction and in amortizing element. Under idea of springing mass whole mass of all elements of suspension is understood. Additionally properties of dampen and springy of tires are considered.

This is important because ability of tires able to dampen of trembling resulting of microstructure of surface majorities. The remain part of trembling are passed on plastic elements of suspension.

After writing suitable dynamic equations simulation model are created.

This will permit on calculation on basis of exit data extortions required in projecting coefficients which in more far part will permit on creating the already concrete geometrical models of suspension and received values of strengths will be to stamina enumerations basis.

The dynamic equations describing the scheme of suspension:

$$M_1 \frac{d^2x_1}{dt^2} + B_1 \left(\frac{dx_1}{dt} - \frac{dx_2}{dt} \right) + k_1(x_1 - x_2) = F \quad (8)$$

$$M_2 \frac{d^2x_2}{dt^2} + B_2 \left(\frac{dx_2}{dt} \right) + k_2x_2 + B_1 \left(\frac{dx_2}{dt} - \frac{dx_1}{dt} \right) - k_1(x_2 - x_1) = 0 \quad (9)$$

After rearrange an equations:

$$\frac{d^2x_1}{dt^2} = \frac{1}{M_1} F - \frac{B_1}{M_1} \frac{dx_1}{dt} - \frac{k_1}{M_1} x_1 + \frac{B_1}{M_1} \frac{dx_2}{dt} + \frac{k_1}{M_1} x_2 \quad (10)$$

$$\frac{d^2x_2}{dt^2} = - \frac{(B_1 + B_2)}{M_2} \frac{dx_2}{dt} - \frac{(k_1 + k_2)}{M_2} x_2 + \frac{B_1}{M_2} \frac{dx_1}{dt} + \frac{k_1}{M_2} x_1 \quad (11)$$

Where:

- M_1 - springy mass,
- M_2 - non-springy mass,
- x_1, x_2 - dislocation masses,
- k_1, k_2 - spring constant,
- B_1, B_2 - damping coefficient.

Below is the operating scheme of the arrangement

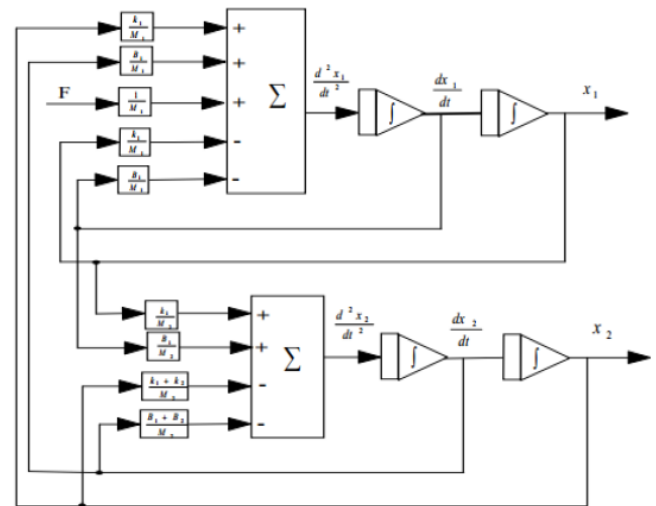

Fig. 3 Scheme of the mechanical operation system.

7. Selection of materials and technological process of production body

First stage of process of projecting the proper selection of factor of safety suitable optimization of material structure and planning the technological process. This obtainment will assure of desirable stamina properties of body and weight. During carrying out of stamina analysis it is essential element the selection of the most profitable factor of safety to the relation of safe stress to permissible do not cause the increase of mass of vehicle. The reduction of mass will cause visible decrease the tires resistances of friction about surface and decrease the losses of energy. The stamina analysis will becomes conducted near help of ANSYS programme. The correct realization of solid figure is in programme the basic condition of realization of investigation of stress of construction the CAD. It is possible to transfer without problem to programme ANSYS and to achieve analysis such model. The good creation of model is important to effective and correct realization by programme of mesh of elements. The last stage of stamina projecting is subtract the degrees freedom and correct applying forces.

In the end of XX century become a growth of interest of composite materials. This results first of all with advantages which they possess such as:

- low proper weight; they used to production of catamarans, rockets, airplanes,
- low thermal conduction,
- resistance on corrosion,
- easiness in creation of difficult constructions from composite materials,
- great resistance on cracking and local damage.

From this regard constructions from composite materials are suitable to the production of body of car taking part in competition World Solar Challenge ideally. The main aim of them use is easy imitation of complicated shapes, mass reduction and large mechanical endurance. The body will monobuilt construction (monocoque) created form composite fibrous materials.

Characteristic mark of every composite is Young module defined by:

$$\frac{1}{E_k} = \frac{f_0}{E_0} + \frac{f_w}{E_w}$$

Where:

E_k - Young's modulus od composite material, E_0 – Young's modulus of matrix, E_w – Young's modulus of fiber.

Use of such construction possible the reduction is the mass and assurance of suitable stiffness of vehicle. Elimination frame will permit on better use space inside the vehicle. The use of composite materials to building the body will not permit to installing other components to the suspension. The only one solution is applying of auxiliary frame to which the elements of suspension will be mounted.

The body will be created from laminate. This will be sandwich construction which have good stiffness and endurance of construction. The quality of laminate is important of his thickness. As laminate is fatter then values of compressive and tensile force are smaller. Such composition consists from layer of coal fiber, sandwich and kevlar fiber.

All these layers are joint by resin. The coal fibre comes into being in result the pyrolysis. It be produced from artificial polymers or natural, tar and phenol resins. Coal fibres have very high tensile strength which is about 1800 [MPa]. They are built from arrayed in two-dimensional layers hexagonal arranged in stacks about thickness to 10 [nm].

Tab.1 Properties of most often using fibres.

| Fibres | Density [Mg/m ³] | R _m [MPa] | E [GPa] | Fusion temp. [°C] |
|-----------------------------|------------------------------|----------------------|---------|-------------------|
| Polymer | 1,44 | 4,4480 | 124 | 86 |
| Kevlar | 1,14 | 825 | 2,8 | 2,46 |
| Metallic | | | | |
| Wolfram | 19,40 | 4,00 | 3,410 | 21 |
| Glass fibre | 2,55 | 3,450 | <1,725 | 28 |
| Carbon fibre | | | | |
| HS (high resistance) | 1,75 | 5,650 | 3,700 | 158 |
| HM (high stiffness) | 1,90 | 1,860 | 3,700 | 279 |

The sandwich have honeycomb structure. Honeycomb are polypropylene materials and use them to production of motor truck building. The sandwich is built from aluminum core of hexagonal shape cover from up and down thin metal foils, which protect before getting through resin inside of core. This permits on full control of process laminating and assures the obtainment the put mechanical properties. The small mass is advantages of this type of sandwich by behavior of high quality of construction and high the stiffness.

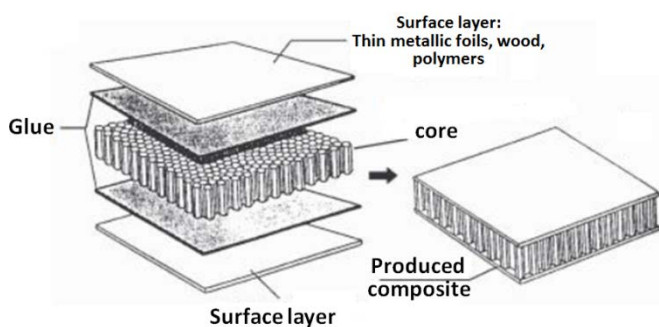

Fig. 3 Scheme of composite building of honeycomb structure.

The aramid fibres are the strengthening fibres, the built from linear, regular and stiff chains of para-fenylene terephthalamide particles. They have very extremely arrayed coating joint with very strong hydrogen bonds structure. The structure of aramid fibre have high physics-mechanical proprieties and high the thermal resistance. Kevlar fibres possess unfortunately small endurance on compress therefore they are strengthened by example coal fibres or glass fibres. They have good fatigue strength, resistance on grinding, large energy of destruction and good electric proprieties. Resin is last element of laminate, which is mentioned above is a part of adhesive. Epoxy resin will be applied which is built from polyphenols, epihlorohydrin and oligomer which have on the ends enrolment formations. Resin have the structure of sticky liquid after

confusion with hardener and becomes indissoluble and infusible after congealing.

The technological process of production of body consists from several stages, which every requires the exact preparation as well as efficiency manual. First part of whole process depends on producing foamed polystyrene form. The foamed polystyrene blocks of links oneself in one cuboid with the help of the suitable binder.

This binder is sewed on the centers of blocks to during formation of block from foamed polystyrene by the hot resistor wire did not happen break of continuity of his movement. To get suitable shape, model is polished and spatula is sewed on him. The putting on him the ground coat and lacquer is the next stage of creating of form. In aim preparation to laminating one should to degrease and to put on external surface of form the funnel. This will assure easy break of form made from fibre glass and gel coat from foamed polystyrene model. Gel coat is he outside part of polyester glass laminate. He is useful high durability, aesthetical appearance and resistance on atmospheric factors. It is proper to mark it that before laminating on form should draw the line of section of form to receive the bottom and upper part of model. After end of laminating need to degrease and to plot on half of form the distributor again. The last stage of building of body is realization of laminate is from coal fibre, separator and aramid fibre. In this point on fabric made from coal fibre put to form and moisten with resin. Then in earlier moisten with resin in indicated places add separator which also moisten resin. Next phase of laminating is position earlier moisten resin of sheet from aramid fibre. To receive the dull internal surface of body on kevlar put delaminate. Whole need be cover cotton-wool and foil. By compressor the air is siphon off so whole excess of resin could sink and during coagulation of resin it do not come to cramp of laminate. After realization both half of body of links oneself it from internal side the cellulose glue.

Acknowledgement

This work has been supported by the MNISW/2014/DIR/374 GP II

8. References

1. Clark S. K., Dodge R. N.: *A handbook for the rolling resistance of pneumatic tires*, University of Michigan, 1979,
2. Reński A.: *Budowa samochodów. Układy hamulcowe i kierownicze oraz zawieszenia*, Oficyna Wydawnicza PW, Warszawa, 2004