

THE BATCH-COMBINED MINIMUM TILLAGE FARMING MACHINE

ПАКЕТНО-КОМБИНИРОВАННАЯ СЕЛЬСКОХОЗЯЙСТВЕННАЯ МАШИНА ДЛЯ МИНИМАЛЬНОЙ ОБРАБОТКИ ПОЧВЫ

Prof. Dr. Samadalashvili A.
Akaki Tsereteli state University, Kutaisi, Georgia
albertsamada@gmail.com

Abstract: *The working members of the batch-combined machine for minimum tillage and crop tending are combined into two separate batches. By means of the first batch, there are performed simultaneously tilling and sowing operations, but the second is intended for surface tillage and crop tending. During just one field day, the machine is capable of performing 8...10 agricultural operations, and its working members can work in three modes: 1. Soil loosening without furrow slice overturning, when the main tillage unit (wedge) is in its working condition together with lateral knives (for the eroded soils); 2. Clod furrow slice pulverization and mixing, when the main tillage unit (wedge), lateral knives and rotary tiller are in their working conditions (for the non-eroded soils); 3. Cultivation of humid soils with a partial overturning of furrow slice, when the main tillage unit (wedge), lateral knives and rotary plough (instead of tiller) are in their working conditions. The cost of oil and lubricants and operating time are reduced by 2...2,5 times, and besides, the agrotechnical terms reduce considerably. The design formula for tillage output envisages both broken and unbroken soil strips. This formula can be also used for calculation of the machine output during cultivation, sowing, cutting the irrigation channels and so on. The proposed batch-combined machine can be also considered as energy-saving, resource-saving, environmental and advanced technology.*

Key words: TILLAGE; CULTIVATION; FERTILIZER; HERBICIDE; IRRIGATION; KNIFE; WEDGE; PLOUGH; ROLLER; SUBSOIL PLOUGH

1. Introduction

As is known, multiple field days of tillage combines for performing agricultural operations lead to considerable soil consolidation and its dispersion. Thereat, soil strength increases, capillarity and moisture capacity go down and seeding time increases that in turn, causes reduction in yields. It is therefore necessary to develop and put into operation the combined tilling machines allowing performing several agricultural operation and processes simultaneously during one field day.

In the light of the foregoing, we have developed the so-called batch-combined strip tilling and crop tending machine, which is capable of performing 8...10 agricultural operations simultaneously during just one field day. These operations are as follows: ploughing (rotary tillage and loosening), expansion and deepening of tilled strip for the purpose of expansion of feeding canals and weeding; tilled soils harrowing; sowing; injection of friable mineral fertilizers into soil (both underground and surface ones); cultivation of border strip; making irrigating channels;

injection of organic and mineral fertilizers into soil (both underground and surface ones); cutaway of backs from the walls of border strips and throwing them into the tilled strip); injection of herbicides or sprinkling of plants with pesticides; breaking of clods and packing; soil furrowing and cutting of track for tractors large bogie wheels.

2. Preconditions and means for resolving the problem

The working member of strip tilling of soil comprises the passive (the main ploughing device – wedge) and active (rotator plough) working members, which working separately or simultaneously, perform strip tilling of soil. In this case, there cultivated not the full area, but just a soil strip of a certain width ($b=15...30$ cm) and depth ($a=15...25$ cm), which is intended for seeding or planting (Fig.1). But in other unbroken strips, soil "rests" and it will be tilled in the following years.

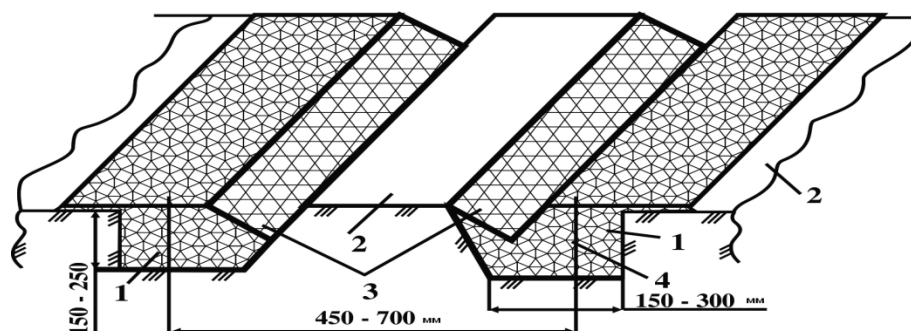

Fig. 1. Scheme of strip tilling of soil
1 – Broken strip; 2 – Unbroken strip; 3 – Irrigation mini channels; Seed.

It is known that the working members of soil tilling machines are shaped as a wedge, since for breaking of material by wedge by using the relatively less force, which is directed along the wedge, it

possibly to obtain a large force, which breaks up material into several parts. Thus, the wedge is considered as an efficient working

member, and that is why we have used the wedge as a main plough share.

Fig. 2 shows the scheme of strip tilling-sowing and crop tending batch-combined machine, the driving members of which are combined in the so-called two batches. The first batch's driving members 1 perform the tilling-sowing operations, and the driving members of the second batch – the cultivation of soil between the rows, cutting of irrigating mini channels, injection of fertilizers and herbicides, aerosol nutrition of plants and compaction of tilled strips.

The first batch's working members operate in the following manner: by means of adjustor nuts 18 and 21 of the main plough (wedge), after adjusting the soil entry angle, during the motion of the aggregate, together with lateral vertical 13 and tilled strip expanding knives 12, cut into soil and perform strip tilling of soil. In particular, by means of the main plough 11, there occurs horizontal cutting of soil layer, its vertical lifting, loosening and movement on its surface toward the cutter knives. The cutting of soil layer lifted by the main plough is completed by means of lateral vertical knives 13 vertically on the both sides (Fig.3), but the expanding knives cut – cutaway of backs from the walls of the border strips with a certain angle, and expanding of tilled strip at the side of soil surface. When the soil layer moving on the main plough, reaches the cutter's knives, there begins its breaking and throwing into empty soil, which is cut from behind. Throwing of clods is limited by metal net 25 fixed to bracket 20, on which after colliding of clod thrown by cutter's knives with net, it will be more broken thrown into the tilled strip, but the thin particle of soil, which will pass through the net, will lay on the surface of tilled soil and will provide an even top surface and thinness of particles. The filled out strip is harrowing by harrow 9 and then there occurs seeding. By means of anchoring seeder 8 and subsoil disrupter 10, which is fixed to the top of the main plough 11, the deepening of tilled strips' bottoms at the depths of 5...8 cm is completed.

Between the lateral knives 13, there is inserted the shaft 15, on which by means of splines there is mounted substitute in kind of clod (soil layer) ripper, an active working member 14, for example cutter or rotary plough. Besides, the driving shaft 15 with reduction

gear unit 17 and cardan drive 16 sets in driving from power take-off shaft of tractor.

The designations of the first batch's working members and other elements are shown in Fig. 1.

The second batch's working members operate in the following manner: together with operation of the first batch's driving members, there operate the second batch's driving members as well. In particular, the soil cultivation in the border strips is carried out at a small depth (1,5...3 cm) by means of arrow-like universal hoes 26, or by herbicides 36. Two hoes are fixed to cutter 27, and one – to cross member of machine's frame 1.

The backs of border strip cutaway by means of tilled strip expander 12 (Fig.2, Fig. 3), are cut again by knife 27 with a certain width and angle, and then by means of blade 28 fixed to it, are throwing into the tilled strip that results in creation of cut irrigating mini channel 44 (Fig. 2), which can be used as an irrigator by tracks as well as for drop irrigation, for placing of drop rubbery hoses in it.

By means of needle-like gear breaking-ramming rollers 33, on the strip tilled surface there could happen breaking of clods and ramming, but with a lateral ramming roller (or sledge-like shield) 34 mounted on it, there is performed ramming of slopes of irrigating channels (or restriction of ground brought down into the irrigating track).

By means of guiding slot cutters 29, on tracks of tractor wheels in the border strips there could happen cutting of slots at a depth 25...30 cm (during the first passage – until 20 cm, during the second and third one – until 5,5 cm), which are intended for better orientation during motion and increasing service speeds during execution of following operations, during the repeated passage, as well as for better irrigation of soil near the roots by using the mini channels.

On tracks of tractor wheels, whereupon the soil the slots are cut, by means of plough working member 39 (Fig. 3), there could be cut the track with a depth of 4...6 cm and width of 20...30 cm, which is intended for quick finding and orienting of the moving direction of tractor aggregate during the repeated passage for execution of following operations (constant track).

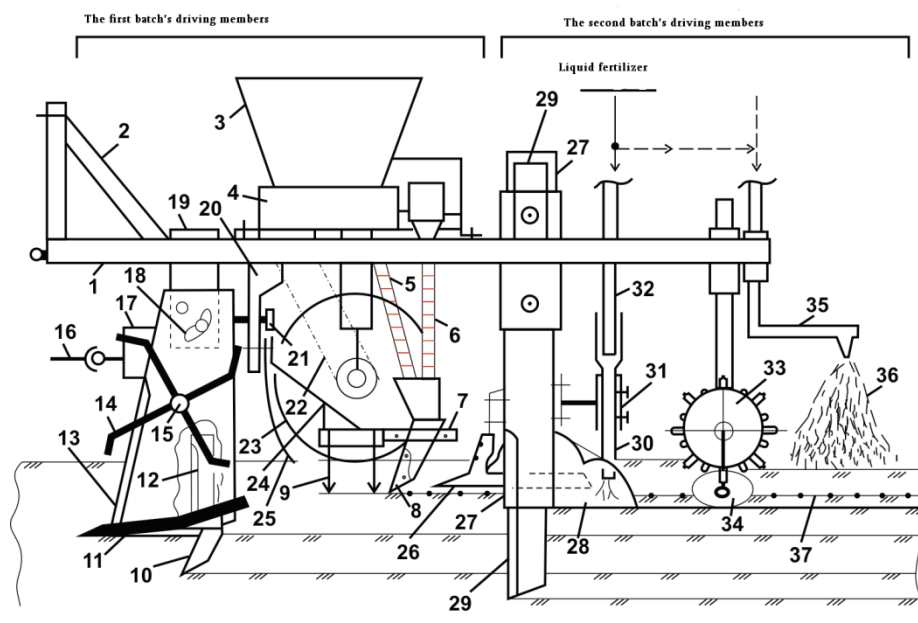

Fig. 2. The Scheme of Batch-Combined Machine for Strip Tilling-Sowing and Crop Tending:

The first batch's working members: 1 - Frame; 2 - Suspension; 3 - Receptacle for seeds and fertilizers; 4 - Sowing device for seeds and fertilizers; 5 - Fertilizer pipeline; 6 - Seed pipeline; 7 - Seeder securing bracket; 8 - Anchoring seeder; 9 - Spike-tooth harrow; 10 - Subsoil disrupter; 11 - The main plough (wedge); 12 - Lateral expanding knives; 13 - Lateral vertical knives; 14 - Cutter knives; 15 - Cutter shaft; 16 - Cardan drive; 17 - Cutter reduction gear unit; 18 - Adjusting screw with oval slot for soil entry angle of the main plough; 19 - Securing bracket for plough member on the frame; 20 - Bracket; 21 - Foot screw; 23 - Journal and adjusting wheel; 24 - Harrow and seeder securing bracket; 25 - Clod throwing limiting net. **The second batch's working members:** 26 - Cultivator arrow-like universal hoe;

27 – Irrigating mini channel cutting knife with blade (28); 29 - Guiding slot cutter; 30 – Liquid fertilizer metal pipeline; 31 – Securing bracket; 32 - Liquid fertilizer rubbery pipeline; 33 – Needle-like-gear breaking-ramming roller; 34 – Ramming roller (or sledge-like shield); 35 – Sprayer bar; 36 – Pesticide; 37 – Seed (fertilizer).

Injection of herbicides 36 or aerosol nutrition of plants is carried out by means of sprayer 35.

By means of ploughing driving member of batch-combined machine, it is possible to carry out strip tilling at three modes as follows: 1. Loosening of eroded soil, with no overturning of clod, when the cutter 14 is turned off and is in operation, together with the main plough 11, lateral vertical knives 13, expanding knives 12 and subsoil disrupter 10; 2. Tilling of non-eroded soils,

with breaking and mixing of clods, when the main plough 11, lateral vertical knives 13 and tilled strip expanding knives 12, subsoil disrupter 10, and an active driving member – cutter 14 are in operation; 3. Cultivation of humid soils by partial overturning of clod, when in operation are the main plough 11, lateral vertical knives 13 and expanding knives 12, subsoil disrupter 10 and rotary plough, which will be mounted on the shaft 15 at the place of cutter 14.

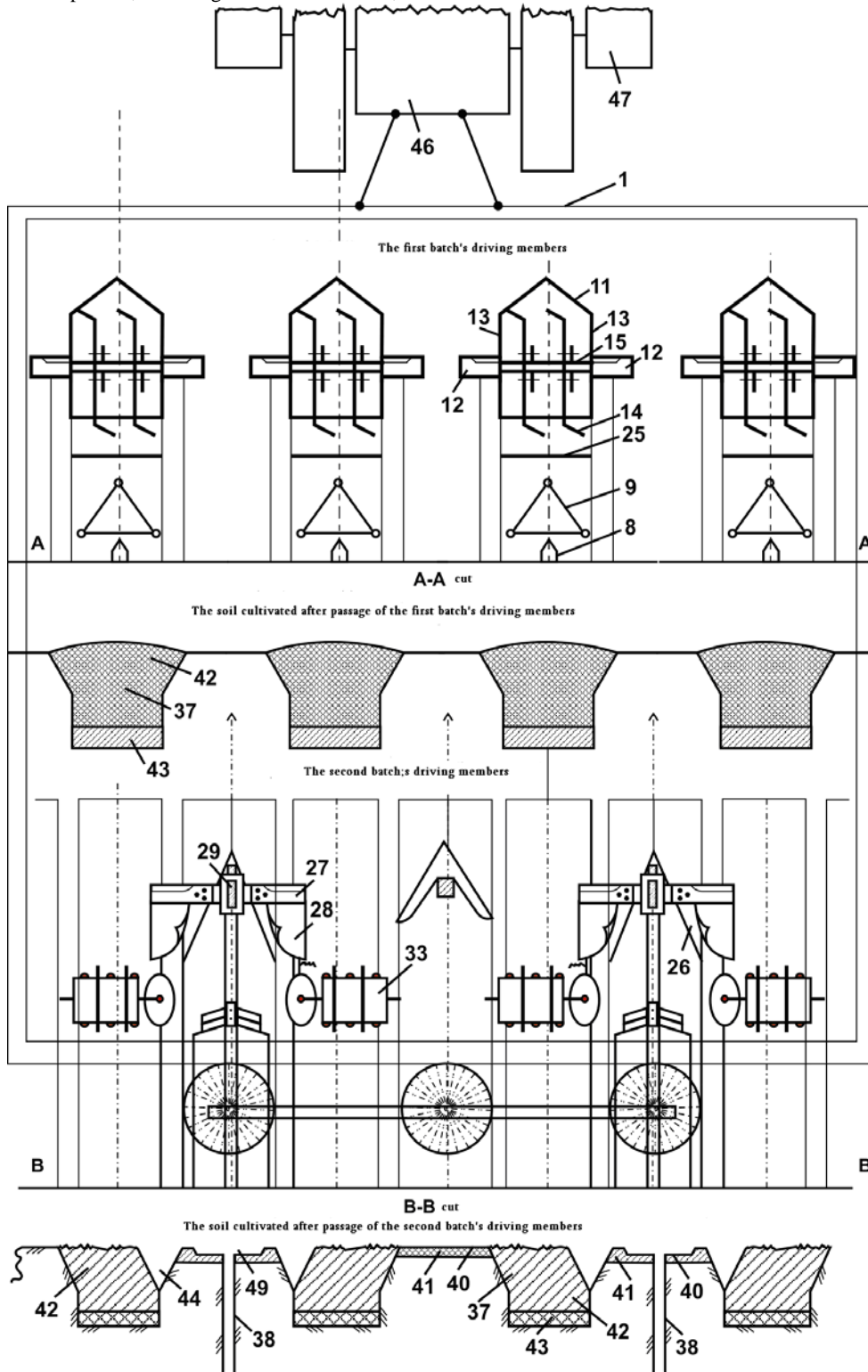

Fig. 3. Mounting Arrangement of Driving Members of Batch-Combined Machine:

1 – Frame; 8 – Anchoring seeder; 9 - Spike-tooth harrow; 11 – The main plough (wedge); 12 – Tilled soil lateral expanding knives; 13 - Lateral vertical knives; 14 – Cutter knives (cutter); 15 Cutter shaft; 25 - Clod throwing limiting net; 26 - Cultivator arrow-like universal hoes; 27 - Irrigating mini channel cutting knife; 28 – Channel cutting knife blade; 29 - Guiding slot cutting knife; 33 - Needle-like-gear breaking-ramming roller; 34 - Ramming roller (or sledge-like shield); 35 - Sprayer bar; 36 – Sprayed pesticide; 37 – Seed; 38 – Guiding slot; 39 – Track cutting device; 40 – Herbicide ribbon; 41 – Soil cultivated by cultivator hoes; 42 – Tilled strip; 43 – Soil broken by subsoil disrupter; 44 – Irrigating mini channel; 45 – Soil cut by track cutting device (39); 46 – Tractor; 47 – Spraying aggregate.

Based on the above stated considerations, it is possible to make the following conclusions:

In case using the wedge as a main ploughing unit, for soil loosening there is required a force, which is by several times less than when using other tilling working members, for example, when using ordinary ploughs. Hence, the cost of oil and lubricants and operating time are reduced by 2...2,5 times. That is why it is considered as energy-saving and resource-saving working member (machine).

When using the combined tilling working members we developed, the hourly efficiency at strip tilling of soil can be calculated the formula, which we also developed recently (according to Fig. 1)

$$W_q = 0,36 V_p [B_0(n-1) + B_p \cdot n],$$

where, V_p – is an operating velocity of machine, m/sec; B_0 – is unbroken row's width, m; B_p – one plough-share coverage width, m; n – number of ploughs. As is seen from the formula, the efficiency of the batch-combined tilling machines is considerably higher than during tilling with ordinary ploughs and consequently, lower is the cost of oil and lubricants and environmental pollution that makes them more profitable to farmers and country. So it should be considered not only energy- and resource-saving technology, but the nature-oriented technology (machine) as well.

3. Conclusion

Since the soil between the broken rows “rests” and it will be cultivated in the following years, the thickness of the fruitful in the surface layer of mellow humus layer will be preserved, and the development of the erosive processes will slow down that will result in an increase in productivity. That is why the proposed technology even in a greater degree is a nature-oriented technology.

Due to fact that the share of the eroded soil in the entire area of all arable lands is high, cultivation of soils of various complexity by means of the combined working members at the appropriate modes (there are given above three types of modes with regulation of the tilt angle of a main ploughing unit – wedge), it will be possible to avoid developing the wind and watery-erosion processes. In addition, the resistance of soil during its cultivation by agricultural machine will be reduced, that will result in reducing capacity power of tractor engine, as well as the cost of oil and lubricants required for strip tilling of soil. The released power of engine can be used for increasing the plough-share coverage and operating velocities of machine.

Thus, as a whole, such a soil tilling technology should be considered as energy-saving, resource-saving, nature-oriented rational and advanced technology.

4. Literature

1. E.S. Bosoy, O.V. Vernyaev, N.N. Smirnov, O.V. Sultan-Shakh. Theory, design and calculation of agricultural machines. The textbook for students. M., Mashinostroyeniye. 1977,- 568 p.
2. A. Samadalashvili. Soil strip tilling unit (machine). Patent certificate N164, A01 B 13/02, 1997, Bull. N3
3. A. Samadalashvili. Soil strip tilling unit (working member). Patent certificate N454, A01 B 13/02, 1999, Bull. N6
4. A. Samadalashvili. determining efficiency of tilling and other agricultural machines during strip tilling. Georgian patent “Sakpatenti”, certificate N5674. Methodological work. 07.22.2013.