

FERTILIZER PLANTERS FOR RESOURCE-SAVING CULTIVATION TECHNOLOGIES IN THE CONDITIONS OF NORTHERN KAZAKHSTAN

Aduov M.A., M.I. Matyushkov, Nukusheva S.A.
S.Seifullin Kazakh Agro Technical University, Astana,
nukusheva60@mail.ru

For the purpose of cultivation of grain crops in northern Kazakhstan the production of grain drills, cultivators such as SES-6 (SES-12) for sowing after cereal backgrounds for sowing on fallow background - disc seeder FFP-3,6, and wetlands soils – paring plough seeder LDS-6 were developed and mastered. At present, grain crops in Kazakhstan is mainly carried out by these morally and physically obsolete drills, and the development and production of new drills in Kazakhstan practically nobody does.

Leaders in the development and production of such seeding equipment in the world are the company «Accord», «Amazonen», «Horsch» (Germany), «John Deere» (USA), «Flexi-Coil» (Canada), and others.

Some models of above mentioned drills with CMC of these firms have been tested in the 80s in the virgin machinery testing stations. None of these models of planters with CMC did not meet the full agro-technical requirements do not provide the necessary uniformity between seed coulters [1].

Also, the machines of foreign companies are expensive and if possible, the need to produce their own cheap planters and

their availability for low income strata of farmers is essential for the widespread introduction of new soil conservation technologies in the region.

At present, the development of sowing machines is carried out in several areas, including the following: improvement of quality indicators of crop, increase productivity of multi-purpose machines. As noted above, a number of these machines are combined with the processing operations, and the fertilizer sowing [3].

In S.Seifullin Kazakh Agro Technical University at the Department "Agricultural and Grain Processing Machinery" under the direction of Professor Aduov M.A. in addition to drills for direct seeding and minimum seeding, fertilizer drills are also being developed. Stubble and fertilizers seeder, Figure 1 [3] consists of a frame, and fertilizers hopper, support wheel, press wheels, tines with distribution of seeds and fertilizers. Cultivator paws in each row are set at different depths interleaved within 2-3 cm. which increases the efficiency of fertilizer use in the initial period of plant growth and increase crop yields.

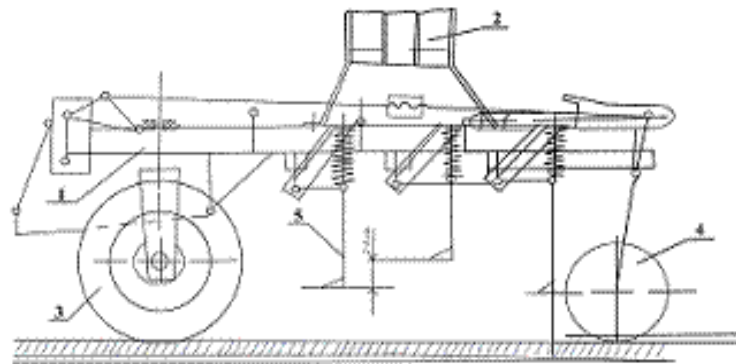

Figure 1 - Stubble and fertilizers drill

1 – frame, 2 - fertilizers hopper, 3 – jockey (full speed) wheel, 4 – press wheels, 5- cultivator sweep.

Seeder works as follows. When driving drills on the field, seeds and fertilizers from mineral fertilizers box come into the furrows formed by cultivator sweeps.

Following press wheels make soil compaction over sown seeds and fertilizers. Mounted at different levels with distributors seed coulters place seeds and fertilizer in different soil horizons. Located in different soil horizons seeds and fertilizers allow the use of fertilizer in the initial period of development that will improve the crop yield

This group also developed ploughshare, Figure 2 [4] which consists of a hollow bar, at the bottom with cultivator point. Front opener is equipped with a rigidly fixed on it above the lower cutoff of cultivator point by side plates made by an exponential curve bevel upward direction in the opposite direction movement of the

ploughshare. Sinkers mounted between lateral guide seed moving relative to the coulter strut in vertical and longitudinal directions.

When driving the opener, fertilizer come to the bottom of the furrow through the hollow rack formed by cultivator point. Covering the fertilizer by the soil is due to soil layer flowing over the counter and repose from the walls of its furrows, seed grain feed crops come in seed guide located in the area between the side plates.

The side plates retract part of moving soil preventing it from closing immediately after the opener, and another part of the soil from existing in the bottom of the bevel is passed into the space between the cheeks for sheltering the bottom of the furrow. Moreover the amount of skipped into the soil goes with the increase from the beginning of the opener to the periphery of the direction of travel opener.

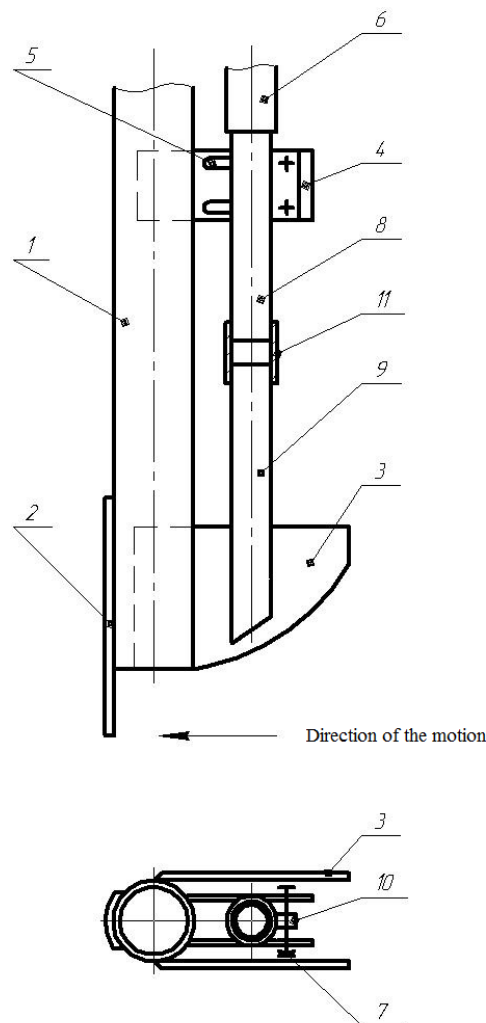

Figure 2 - The opener for the separation mineral fertilizers introduction
 1 – hollow shank, 2 – cultivator point, 3 - side plates, 6 – seed guide, 9 - coupling.

Seeds from the seed guide are sown on the soil layer hide the furrow, thereby made smaller depth of their termination in comparison with fertilizers, which lie on the bottom of the furrow.

Seed placement of grain crops is due to cover their part of the moving soil layer and due to repose of the soil from the sides of the furrow. Seeding depth of grain and grain feed crops is controlled by moving the slots of the seed guide in the bracket horizontally and by shifting it to the bottom of the coupling in the vertical direction.

In this case, the moving seed guide is relative to the coulter strut in the vertical and longitudinal directions, and enables to plug the seeds and fertilizer into the different soil horizons.

Based on the above mentioned it should be noted that the developed and fertilizers drills for resource-saving technologies aimed at modernization (simplification) in general device, increasing the safety factor implementation process and to improve the performance of seeders, minimal disruption of the soil structure to ensure the quality of sowing on moist soils, providing high cross at sowing after cereal backgrounds, with a spacing of 15 cm. In general, the development and introduction of high-performance

drills allow a 20-25% increase in yield from agricultural crops and the introduction of zero and minimum technologies.

REFERENCES

1. M.I.Matyushkov and others. Technologies of zero tillage and direct seeding for the cultivation of crops in Northern Kazakhstan. pp.38-48. Almaty-Astana. 2005.
2. Aduov M.A., Kaspakov E.Zh., Nukusheva S.A. Improving the efficiency of sowing and fertilizers improving its sowing and opener. Proceedings of the International Scientific and Practical Conference Part 2 "Agroengineering science-agricultural production." Kostanai, 2012, Part 2, p.73-78.
3. Innovation patent of RK №83106 Seeder stubble and fertilizers / Authors Aduov M.A., M.I. Matyushkov, Nukusheva S.A. Published in 2014. Bulletin №6.
4. Innovation patent of RK №59284 Seeder / Aduov M.A., Kaspakov E.Zh., Nukusheva S.A. and others. Published in 2009. Bulletin №3.