

CONCEPTION OF NAVIGATION SYSTEM FOR AUTONOMOUS AGRICULTURAL ROBOT

M.Sc. Eng. Jasiński M. PhD.¹, Prof. M.Sc. Eng. Mączak J. PhD.¹, M.Sc. Eng. Szulim P.¹, Prof. M.Sc. Eng. Radkowski S. PhD.¹
Institute of Vehicles – Warsaw University of Technology, Poland¹

jachuu@simr.pw.edu.pl

Abstract: The aim of the paper was to propose conception of the navigation system for the autonomous robot for sowing and wide row planting. Autonomous work of the robot in range of traction and agronomic processes will be implemented on the basis of data from a many sensors (cameras, sensors position, sensors distance, and others). Positive test results will allow for the use of the robot in organic crops requiring mechanical removal of weeds or in crops with application of selective liquid agrochemicals limited to the minimum. The use of a vision system, based on the map coordinates of the position of the sown seeds, will allow for their care on an early stage of plant development. Main sensor system is based on a specialized GPS receiver providing position information with an accuracy of less than 100 mm. This system will be used to: control speed of the robot, guidance and maintenance robot on the designated path, precision seeding - the exact information on where sowing the seeds will be used to build maps of seeds, which will be used as supporting information for precision weeding, and to control the position of and operation of key components. The front camera view will be used to increase positioning accuracy of the robot. It will allow corrections of the robot path regarding the rows of plants. The vision system will also be used for detection of non-moving objects. Additionally information from the acceleration sensors and encoders built-in wheels will be used in navigation purposes. To determine the angular acceleration the IMU (Inertial Measurement Unit) will be required. During the preliminary phase of the project Authors are planning to test possibility of usage of several low cost sensors for collision avoidance system (moving objects detection).

Keywords: AGRICULTURE ROBOT, CARE OF PLANTS, AUTONOMOUS WORK, COLLISION AVOIDANCE METHOD

1. Introduction

Syndicate of Industrial Institute of Agricultural Engineering in Poznań, with the Institute of Vehicles of Warsaw University of Technology and PROMAR company from Poznań was started a design of autonomous farm robot for sowing and cultivation of wide row planting.

The aim of the project is to develop structures and operation procedures autonomous robot for sowing and wide row planting and conducting laboratory and exploitation tests on an experimental model. Autonomous work of the robot in range of traction and agronomic processes will be implemented on the basis of data from a many sensors (cameras, sensors position, sensors distance, and others). Positive test results will allow for the use of the robot in organic crops requiring mechanical removal of weeds or in crops with application of selective liquid agrochemicals limited to the minimum. The use of a vision system, based on the map coordinates of the position of the sown seeds, will allow for their care on an early stage of plant development. The applicability of the robot to onerous work in organic farming may encourage farmers to discontinue the use of herbicides in crops include sugar beet, corn, etc..

2. Initial assumptions for robot

The autonomous farm robot should work in following working conditions:

- terrain: empowered field, field roads, mud, sand, grassy ground, rocky ground or other hardened,
- work in the open 24 hours / day,
- work in areas with varying degrees of lighting and visibility,
- temperature: 5 to 40 ° C,
- weather: average rainfall, moderate wind, fog,
- typical obstacles in the open area.

Projected robot enables complex care field crops including:

- red beet,
- sugar beet,
- sweet corn,

- cabbage,
- lettuce,
- forest nurseries, orchard,
- production of vegetables and ornamental plants.

Projected robot will enable complex care of field crops including: red beet, sugar beet, sweet corn, cabbage, lettuce, forest nurseries, orchard, production of vegetables and ornamental plants. Additionally it should enable the mechanical destruction of weeds and, if necessary, precise application of crop protection formulations and fertilizers. Robot constructed by us will be have a smart weeders, equipped in LPS system, which uses digital image analysis for steering working tools, for mechanical weed control^{1,2}.

CAD Model of the robot was presented at figure 1.

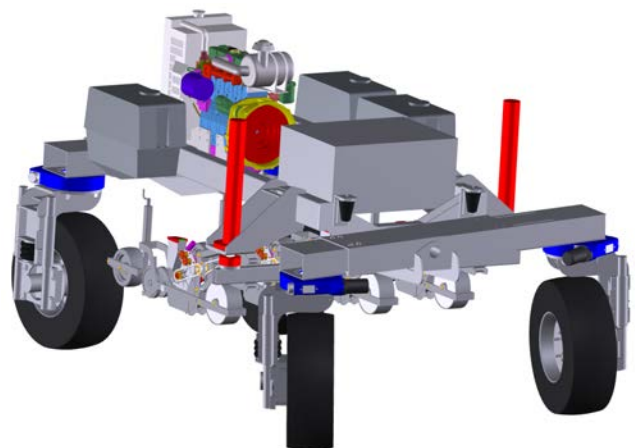

Fig. 1 CAD Model of the robot²

3. Conception of navigation system

Main sensor system is based on a specialized GPS receiver providing position information with an accuracy of less than 100 mm. This system will be used to: control speed of the robot, guidance and maintenance robot on the designated path, precision seeding - the exact information on where sowing the seeds will be used to build maps of seeds, which will be used as supporting information for precision weeding, and to control the position of

and operation of key components. For tests a typical GPS (10 Hz) will be used.

The front camera view will be used to increase positioning accuracy of the robot. It will allow corrections of the robot path regarding the rows of plants. The vision system will also be used for detection of non-moving objects. Simultaneously second vision unit will also be used for acquiring camera images immediately before active hoes and sprayer. Additionally information from the acceleration sensors and encoders built-in wheels will be used in navigation purposes. To determine the angular acceleration the IMU (Inertial Measurement Unit) will be required. This will enable a:

- trajectory correction of the robot,
- precise work of active hoe,
- position adjustment and precise dosing of liquid fertilizer plant health products.

The exact position of the robot is obtained from the fusion of signals from precision GPS (in the test version standard GPS receiver Ublox NEO7) and integrated system of inertial and magnetic sensors VN-100³. VN-100 is a complete AHRS (attitude heading reference system) system integrating measurements from three axial sensors: acceleration, angular velocity and Earth magnetic field. All of the sensors have temperature compensated sensitivity and common values. Moreover, all the skewness of axes were calibrated. VN-100 device provides accurate information from all the sensors and estimates of the spatial orientation angles, DCM (direct cosine matrix) transformation matrix, and estimated values of linear accelerations and angular velocities in the absolute coordinates (NED – north/east/ down) independent from the angular orientation of the sensor. It is planned that two AHRS systems will be placed on one machine: first related to the vehicle and the second with a connection to the tools (e.g. seeder). AHRS integrated with the vehicle will provide the detailed momentary angular orientation and acceleration of the body while the second set allows better estimation of the momentary position of the tool thus allowing precise localisation of the seeds. Detailed information about their positions, stored in the internal database, will be used in further fieldwork related to the care of plants.

During the preliminary phase of the project Authors⁴ are planning to test possibility of usage of several low cost sensors for collision avoidance system (moving objects detection):

- HC-SR04 (Cytron Technologies) ultrasonic distance sensor with range of 5m. The HC-SR04 ultrasonic sensor uses sonar to determine distance to an object like bats or dolphins do. It offers excellent range accuracy and stable readings in an easy-to-use package. Its operation is not affected by sunlight or black material.
- 360 Degree Laser Scanner Development Kit. RPLIDAR is a low laser scanner (LIDAR) solution developed by RoboPeak⁵.

2D Laser Scanner (LIDAR) test

360 Degree Laser Scanner Development Kit. RPLidar is a low laser scanner (Lidar) solution developed by RoboPeak. The system can perform 360 degree scan within 6 meter range. The produced 2D point cloud data can be used in mapping, localization and object/environment modelling. It measures just over 2,000 times per second with a very small measurement error of less than 1% - theory. Real mistake approx. 10%. Temperature -10 ° C to 40 ° C - theory. Research at -8 ° C - refreshing decreased significantly, the error up to 20%.

RPLidar measurements with error were presented at Fig. 2 and in Table 1.

The advantages of laser RPLidar includes:

- Low cost

- Large technical support from the manufacturer
- Small dimensions
- Trouble-free detection of objects

Detecting moving objects

RPLIDAR Disadvantages:

- Huge error of distance measurement
- Improper operation in extreme temperatures and strong sunlight
- Incorrect measurements with increased wind power
- Vibrations of the drive mechanism

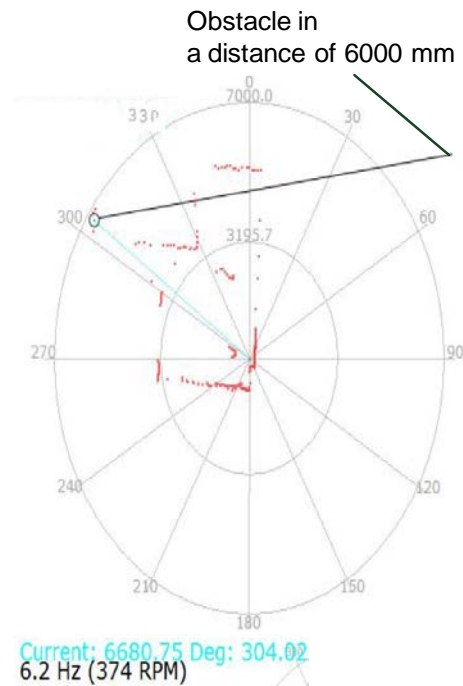

Fig. 2 RPLidar measurement

Real measurement	RPLidar measurement	Difference
500	577	77
1000	1146	146
1500	1605	105
2000	2192	192
2500	2756	256
3000	3377	377
3500	3779	279
4000	4333	333
4500	4801	301
5000	5405	405
5500	6054	554
6000	6680	680

Tab. 1 Real vs RPLidar measurements difference

3. Conception of the collision avoidance system

The collision avoidance problem can be divided into two different subproblems: detecting the obstacle and bypass the obstacle^{6, 7}.

The raw measurements from Laser scanner 2D are at first transformed into Cartesian coordinates⁸. The obstacles are detected from the transformed measurements using clustering method. The whole clustering process is illustrated in Fig. 3. The initial positions for the clusters are gained from the set of known obstacles. The

cluster initial position is added if known obstacle is in sight of the scanner.

The path tracking method is based on the Nonlinear Model Predictive Control. Vougioukas⁹ has used the Nonlinear Model Predictive Control (NMPC) method to control the position of the vehicle. Moreover, the collision avoidance was included into the controller by using additional cost from distance sensor readings. The controller was able to follow a predefined path as well as avoid collisions with static obstacles. The functionality was proven with simulations.

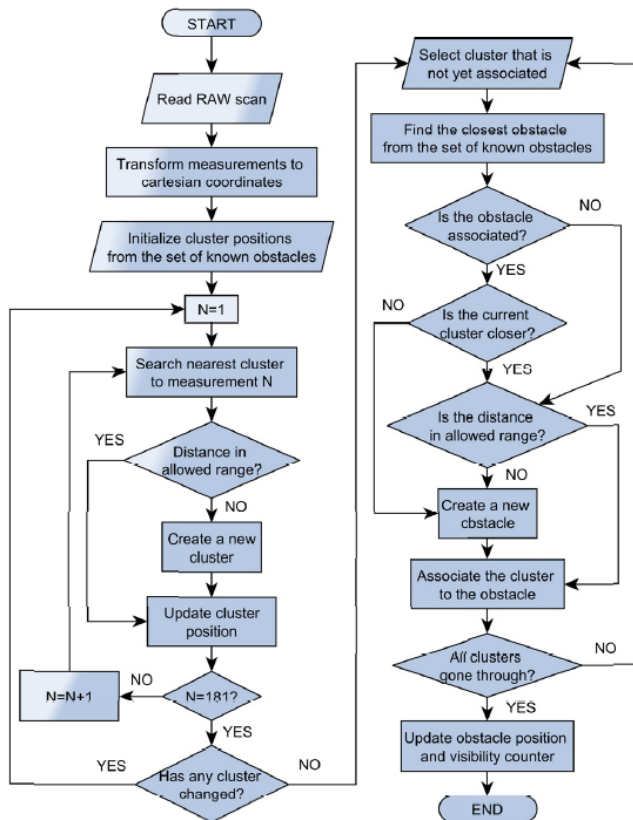

Fig. 3 The clustering algorithm⁸

In the NMPC, the control values are calculated, so that the given cost function is minimized. The constraints of the optimization problem are obtained from the system model and the constraints of the states and control values. There are different ways to include the object avoidance into the NMPC. One way is to add additional constraints to the state values. Another way is to add an additional cost from the obstacles or simply to modify the reference trajectory to go past the obstacle.

In this way, the modification of the cost function was chosen. The underlying path tracking cost function is not changed nor the reference trajectory, but the cost from state is modified. This is because of the calculation capacity and the possibility that the obstacles could move.

When the reference trajectory is near an obstacle, it cannot be followed without colliding to the obstacle. Therefore it is irrelevant to keep the cost from the reference trajectory. Instead a cost that makes the vehicle drive past the obstacle should be added. The obstacle is allowed to be closer on the side of the vehicle.

The calculated distance to the edge of the avoided area is used in the cost function, when the obstacle is inside the avoided area or the obstacle is closer to the avoided area than the vehicle is to the original reference trajectory. the cost is calculated only from one obstacle. If there are multiple obstacles inside the avoided area, the one with the largest value of the the distance from the obstacle to

the edge of the avoided area is chosen. The same methods are also used for the cost from the trailer position.

4. Conclusions

Conception of the navigation system for the autonomous robot for sowing and wide row planting was presented.

Some elements of navigation system was tested: RPLidar 2D and ultrasonic distance sensor .

In the next stages of the project design tasks are planned: selecting the target concept robot based on numerical analysis and developing the concept of the control system and autonomous robot control algorithms

References

1. Jasiński Marcin, Mączak Jędrzej, Radkowski Stanisław, Rogacki Roman, Mac Jarosław, Szczepaniak Jan, Pawłowski Tadeusz: Autonomous agricultural robot - initial assumptions of project. *Zeszyty Naukowe IP*, 102(2), 2015, pp. 49-56.
2. Jarosław Mac, Wojciechowski Jacek, Rogacki Roman, Szczepaniak Marcin: Modelling kinematic and dynamic of wheeled mobile field robot. *Proc. of XV International Technical Systems Degradation Conference*, Liptovský Mikuláš, Slovak Republic, March 30-April 2, 2016, pp. 140.
3. VN-100 Rugged - VectorNav Technologies. <http://www.vectornav.com/products/vn100-rugged> <29.10.2015>
4. Jasiński Marcin, Mączak Jędrzej, Radkowski Stanisław, Korczak Sebastian, Rogacki Roman, Mac Jarosław, Szczepaniak Jan: Autonomous Agricultural Robot — Conception of Inertial Navigation System. Edited by: Szweczyk R., Zieliński C., Kaliczyńska M.: *Challenges in Automation, Robotics and Measurement Techniques. Advances in Intelligent Systems and Computing Vol. 440*, pp. 669-679, 2016.
5. <http://www.robopeak.com> <29.10.2015>
6. Jasiński Marcin, Mączak Jędrzej, Szulim Przemysław, Radkowski Stanisław: Autonomous agricultural robot - collision avoidance methods overview. *Zeszyty Naukowe IP*, 106(2), 2016, pp. 35-42.
7. Jasiński Marcin, Mączak Jędrzej, Szulim Przemysław, Radkowski Stanisław: Conception of the collision avoidance system for autonomous agricultural robot. *Proc. of XV International Technical Systems Degradation Conference*, Liptovský Mikuláš, Slovak Republic, March 30-April 2, 2016, pp. 21-24.
8. Backman J., Oksanen T., Visala A.: Collision Avoidance Method with Nonlinear Model Predictive Trajectory Control. *Proc. of 4th IFAC Conference on Modelling and Control in Agriculture, Horticulture and Post Harvest Industry August 27-30, 2013*. Espoo, Finland. pp. 35-40.
9. Vougioukas, S.G. (2007). Reactive trajectory tracking for mobile robots based on non linear model predictive control. In: 2007 IEEE International Conference on Robotics and Automation, ICRA, Barcelona, Spain. pp. 3074-3079.



Work financed
from NCBiR
years 2014-
2017 funds.

