

# METHODOLOGY FOR CONSTRUCTION OF PERSPECTIVE IMAGE OF AN OBJECT THREE DIMENSIONS

Ch. Ass. eng. Bankova A. PhD., Ch. Ass. Zhecheva G. PhD. - Technical University - Varna, Department of Industrial Design

ina\_janakiewa@abv.bg; ginkaaa@yahoo.com

**Abstract:** This work has been viewed and analyzed architectural perspective as the most commonly used in the construction of perspective images of architectural objects. The following are the basic principles of getting perspective image and elements of perspective construction. Based on methods for building a promising images of points, lines and rectangles lying on the field was built prospect of three-dimensional body - prism. There are two variants in building perspective image: prism - the edge of which falls within the projection plane and perspective image of the prism away from the projection plane.

**Keywords:** ARCHITECTURAL, IMAGES, OBJECTS, PERSPECTIVE, PRISM

## 1. Introduction

The prospect is part of descriptive geometry, which studied the rules and methods of display on a surface of volumes, spaces and forms as they are perceived in reality. Looking ahead image object presents a three-dimensional, with chamfer dimensions in the distance, the same laws by which it perceives the human eye [1,2].

Depending on the shape of the surface on which is built the perspective image, there are various kinds of perspective - construction (architectural), linear, free, angled. An important part of the design is architectural perspective is built by the method of Architects (method of doing). It is widely used in architectural practice for clearly clarifying the volumetric spatial solutions of exterior and interior to assess the proportions, the relationships of the volumes and forms in architectural composition.

For large-scale expression in three-dimensional drawings of volumes and spaces using the method of three-dimensional view [4]. In it there is a voluminous visibility, the scale of the three dimensions - width, length and height - creates practical convenience when working with drawing, but volume is conditional expression and deformed (no reductions in depth) and does not meet the laws of human perception [3,5].

The images built with methods of architectural perspective, are visual, perceived easily, without the need for prior special training and approaching maximum of images obtained from human visual perception. Perspective image is built with precise mathematical methods and its forms, proportions and relationships subject to certain conditions conforming to those who will object after its construction [6].

Fig. 1 depicts a hollow brick in three directions - a) rectangular projection b) perspective view and c) outlook;

Architectural perspective is constructed on the basis of orthogonal projections of the object of his plans, sections and elevations.

In practice perspective the site is usually built in the last stage of the design, but this needs to be inseparable element of all phases of architectural design tool for checking the composition, allowing for timely adding any necessary corrections in the project. As a basic method for building a promising image using central projection that most - fully approaching the peculiarities of human vision. The main principle on which is built the central projection and promising image is directing rays from a visual point to key points of a body. Between the visual point and the body is placed imaginary projection plane in which the piercing points of the beams outline the promising image of the body (Figure 2).

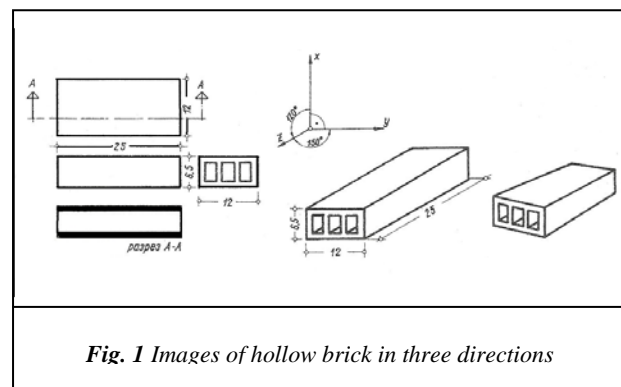

Fig. 1 Images of hollow brick in three directions

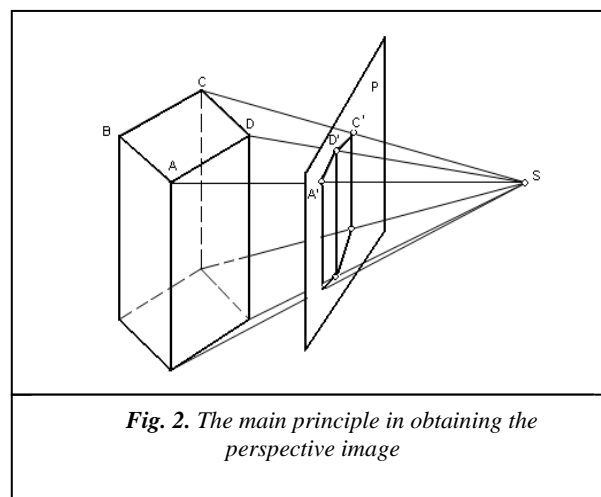

Fig. 2. The main principle in obtaining the perspective image

## Elements of perspective construction

In the construction of perspective image on the plane using an auxiliary system of points, lines and planes that characterizes the basic principle of construction and consists of the following main elements (Figure 3).

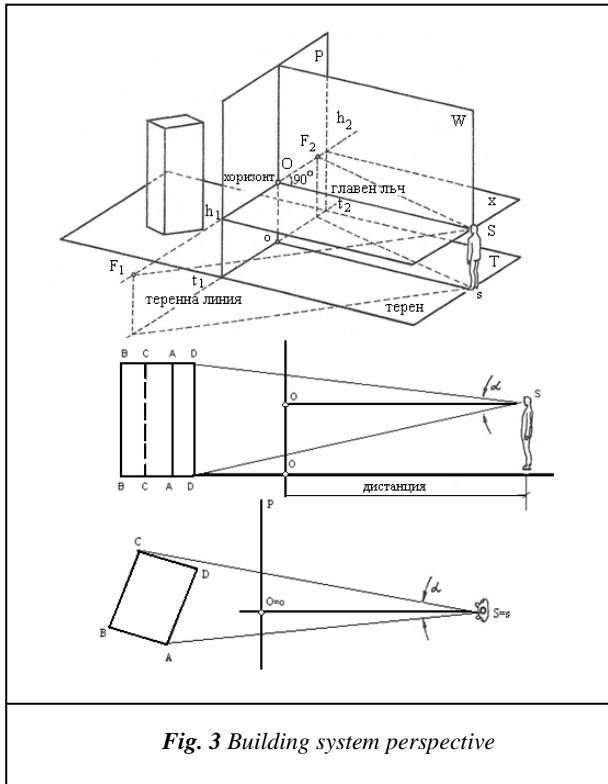

Fig. 3 Building system perspective

- T- field plane;
- P - projection, picture plane;
- X - plane of the horizon;
- W- main vertical plane;
- S- visual point;
- s- point standing;
- O- stab main point;
- O h - projection of the main pierce point of the terrain;
- SO - - main beam;
- SO=so - distance;
- h1-h2 – skyline, horizon;
- t1 - t2 - field line projection plane;
- O-o – master-slave vertical line;
- Ss=Oo – height on the horizon;

F1, F2 – vanishing points; As promising image is constructed in accordance with the characteristics of visual perception, if the angle of the object is - greater than 40°, in perspective image distortion will occur is the image will not give an accurate volumetric representation of the subject. It was found that in the construction of perspective images at a constant height on the horizon, but at angles up to 30° deformations are not detected.

Selecting a visual point is crucial in building a promising image. It is expressed in the establishment of several interrelated elements of perspective:

- The distance between the visual point and projection plane - the size of the gap;
- The position of the main beam;
- The position of the projection plane;
- The position of the horizon line - the visual point is selected so that the target falls within the viewing cone angle of from 30 to 40°.

And the main beam is closer to the axis of the cone;

For determining the angle of view it is necessary to establish the distance z The pierce point to the - remote part of the site (Figure 4) to move into the plan from point A to ao.

The last point descends beam that conclude with the main beam angle  $\frac{\alpha}{2} - 15-20^\circ$ . The intersection of the two beams will be suitable visual point.

Another important factor that depends promising image is the height of the horizon. It is selected from 1,6 to 1,7 m, whatever e the average height of the eyes of an observer standing on the field in front of the object.

Fig. 5 shows how to change the perspective image at different heights on the horizon.

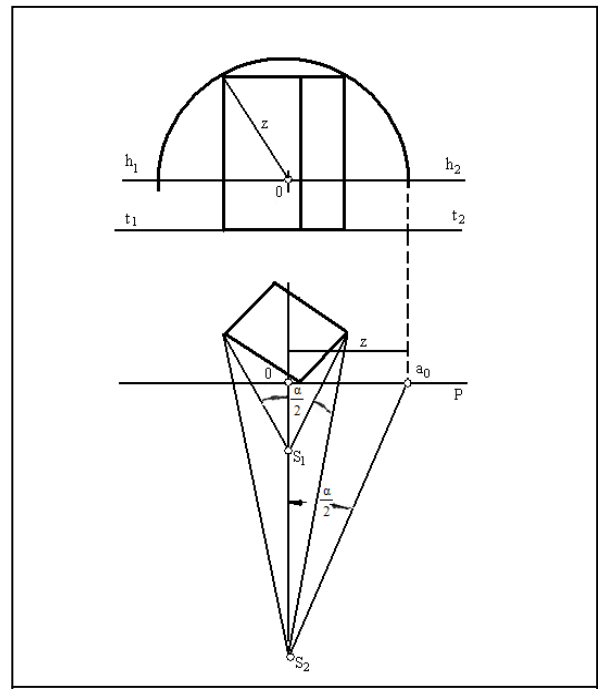

Fig. 4 Determination of appropriate visual point through most - large horizontal or vertical spacing element of the object and a knife point

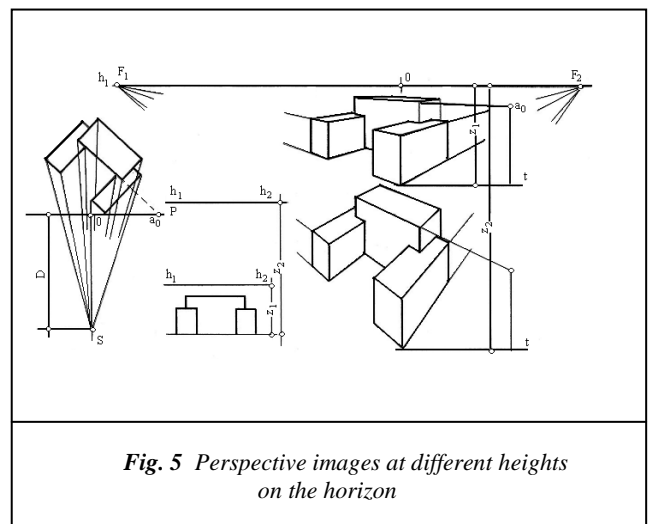

Fig. 5 Perspective images at different heights on the horizon

## 2. Forward displaying objects with three dimensions

Architectural objects are bulky bodies. Finding their perspective image is to build on the promising image of the building plan and finding the height of the vertical elements, after specifying details. Bearing in mind the methods for building a promising images of points, lines and rectangles lying on the ground, enable it to be built and the prospect of three-dimensional body.

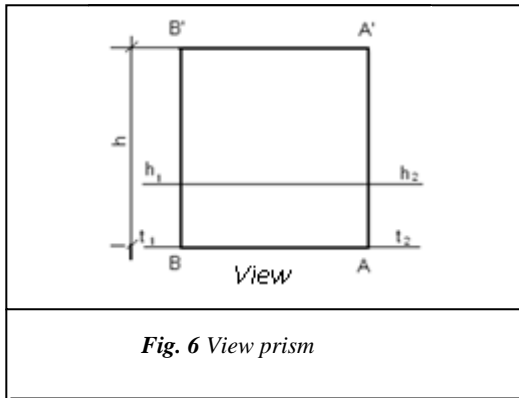

Fig. 6 View prism

Fig. 7 is a prism lying on the ground by one edge of the prism coincides with the projection plane. The prism is defined by the plan of the base and from its view given in FIG. 6. To simplify the transfer of measures of the plan on the perspective image, the drawings are arranged one upon the other with coinciding the direction of the main beam and the main vertical line. The necessary constructions are:

1. We define two vanishing points  $F_1$  and  $F_2$ , and promising image-based prism  $A_1B_1C_1D_1$  by known methods.
2. In  $A_1B_1C_1$  points and  $D_1$  raise vertical lines, which lie corresponding perspective images of the vertical edges of the prism.
3. Edge  $A_1A_1'$  lies in the projection plane, it is true size, point  $A_1$  will lie of field line and point  $A_1'$  rises above it at a height  $h$ , taken from the view prism.
4. Lines  $AB$  and  $CD$  are parallel to  $SF_1$  perspective and their images are routed to the vanishing point  $F_1$ . At the same point will be targeted and promising parallel images of them doing  $A_1B_1$  and  $C_1D_1$ .
5. Crossing the rights  $A_1F_1$  with vertical dropped from  $b_0$  to  $B_1$ , would give the point  $B_1'$ , which is promising image point  $B'$ .
6. In an analogous manner to determine the position and to other points of the upper base of the prism.
7. The resulting image perspective is given in Fig. 7.

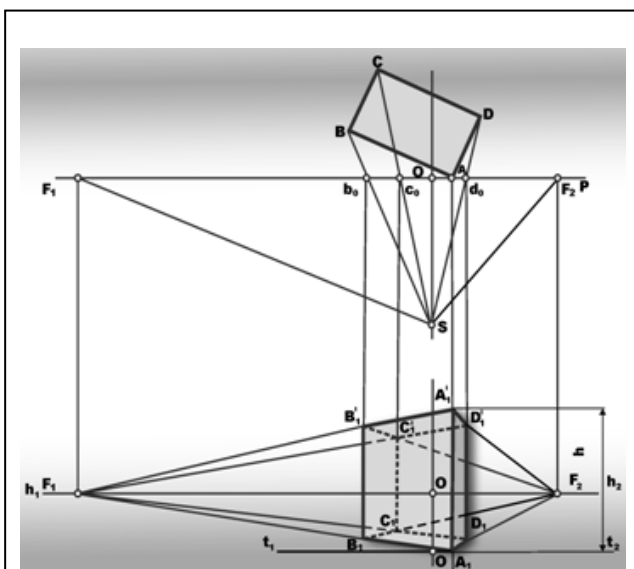

Fig. 7 Perspective image of the prism, the edge of which falls within the projection plane

Figure 8 shows built promising image of prism lying on the ground, but away from the projection plane.

Construction is similar to the above in Figure 7, the only complication is finding perspective height of one of the edges of the prism.

1. Since the elements lying in the projection plane, are in a true size, still each of the vertical sides of the prism, while crosses the projection plane.
2. Received rights in perspective image inflict the appropriate height, taken from view, as measured from the field line up.
3. Rays, descended from endpoints of this vertical line to the appropriate vanishing point will give prospective shortened height of the adjacent edges of the country.
4. Continue drawing the sides  $BC$  minted projection plane in point  $M_0$  from which descend vertically to the terrain line perspective image and inflict on her true height  $h$ , taken from view.
5. The rays of the end points of the respective height of the vanishing point determined position of the points  $M_0$  and  $M_0'$ , corresponding to the vanishing point  $F_2$  define the position of the points  $B_1$  and  $C_1$ , and  $B_1'$  and  $C_1'$ .
6. Continuing country  $BA$ , it will cross the projection plane at the point and no respectively rights  $n_0n_0'$ , which can perform the same operations; It will serve as verification of the constructed image perspective.

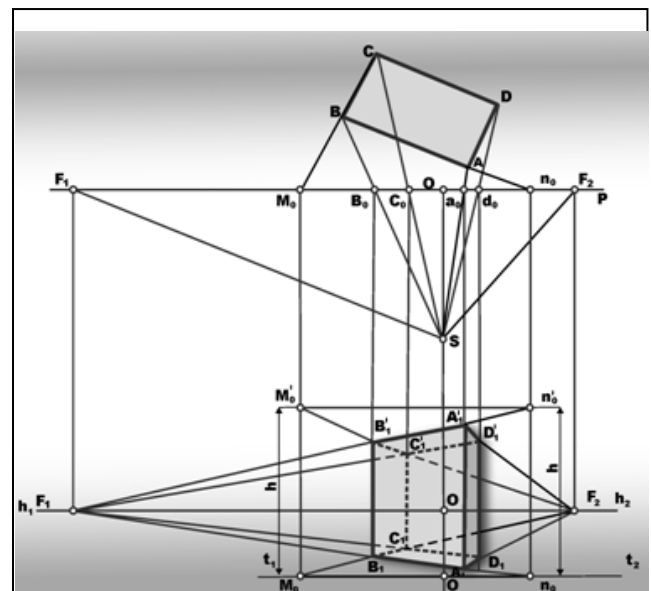

Fig. 8 Perspective image of prism away from the projection plane

### 3. Conclusion

Exhibitions method is the - often applied in finding the heights of the elements. It is also truncated promising heights can be found by constructing perspective images of their end points. Using these multiple repetitive manipulations can be constructed prospects of buildings with complex shapes, elements and details.

The method is widely used in painting, architecture, engineering - civil engineering and more. Each designed building, its interiors and technical objects must be displayed in perspective. In their perspective images can be judged for their appearance, proportion and harmony of individual elements of the expected visual perception of these objects. Perceived by prospective composite image defects can be rectified in the design process.

#### 4. Literature

- [1]. Манакова Г.И., Буторина И. В. Проекции теней. Учебное пособие. Министерство образования и науки Российской Федерации Южно-Уральский государственный университет, Челябинск. 2004.
- [2]. Манакова Г.И., Буторина И.В. Перспективные проекции. Учебное пособие Министерство образования и науки Российской Федерации Федеральное агентство по образованию Южно-Уральский государственный университет Челябинск. 2006.
- [3]. Климухин А.Г. Тени в перспективе. Стройиздат, 1967.
- [4]. Кайгородцева Н.В., Ойдуца Т. В. Перспектива: виды и способы построения Учебное пособие. Министерство образования и науки Российской Федерации Омск,издательство ОмГТУ, 2011.
- [5]. Роженко З.М., Чермных И.А., Адашевская И. Ю., Краевская Е.А и др. Построение перспективных изображений. Методические указания и варианты заданий по курсу “Производственный дизайн и эргономика”, Харьков 200.
- [6]. zen-designer.ru
- [7]. prepod.nspu.ru/mod/resource/view.php?id.
- [8]. Йорданова С., Милев Я., Стоянова Р. и др. Проекционни методи в инженерната графика – ръководства. Изд. „Колор принт”, Варна, 2003.

#### Contact:

Ch. Assist. eng. Aleksandrina Ivanova Bankova,  
Ch. Assist. eng. Ginka Zheceva,  
Technical University - Varna, Dept. ME  
ul.Studentska № 1, tel.383 300  
e\_mail: ina\_janakiewa@abv.bg  
ginkaaa@yahoo.com