

A single-board computer based distributed system for internal and external sound monitoring.

Piotr Książek¹, Karol Buchman¹, Adam Pilch¹
¹AGH university of Krakow, Poland
piotr.ksiazek250@gmail.com

Abstract: This work showcases a distributed noise monitoring system used for measuring noise levels both inside and outside of buildings in urban environments. The system utilises single board computers as main operating units which handle the measurement of parameters and communication. The noise monitoring stations can measure instantaneous and long-term acoustic noise levels, as well as atmospheric parameters such as atmospheric pressure, air temperature and humidity. Measurement stations are connected to an external server via the MQTT protocol. The external server allows for the recording of data into a secure database, as well as for providing end users with historical and instantaneous data on request. A test run of the measurement system was performed and has shown that the measurement stations can function in their design capacity. The system shows great promise in use in internal monitoring of industrial plants both as a precautionary measure for worker health and safety and as an easily modifiable sound monitoring platform in the industry 4.0 standard.

Keywords: ACOUSTIC MONITORING, INTERNET OF THINGS, INDUSTRIAL NOISE, SOUND MEASUREMENT

1. Introduction

Noise in both urban and rural areas has increased in the past century to the point where its impact on human health and well-being is measurable on both a societal [1] and personal scale [2]. The problem is exacerbated by the transportation industry and noise produced in industrial plants, as those activities, which are necessary to our way of life, are omnipresent in urban spaces.

Monitoring the pollution of environments people live in is both mandated by law in many European countries [3] and is gaining popularity as pollution monitoring services make acquiring data pertaining to air quality both easy and convenient for those who are concerned about the impact of pollution on their health. An example of such a system is Airly [4], which provides real-time and historical data from a network of air quality sensors forming a dense network across a wide area. The sensors used by the Airly network are low-cost, easy to install and maintain measurement stations [5], which allows the system to be as widespread as possible.

Acoustic monitoring can be done in an analogous way, as solutions exist for long-term monitoring of sound pressure level. Those solutions, however, are mostly professional class 1 or 2 conforming measurement devices [6], which are costly to deploy en masse and are non-modifiable in their functionality. Previously such systems have been implemented, however most of those attempts do not focus on the integration aspect of such systems [7]. To develop a distributed monitoring system, a new open, and modular device ought to be designed. The main goal of this work was to develop a modular, easily modifiable measurement device capable of monitoring sound pressure levels and environmental parameters. The device was to implement distributed measurement system methodology [8], with all of the signal processing and data manipulation happening on-device. The design steps of the device are explained in the next section, with the software architecture, networking configuration of the system and measurement validation following.

2. Measurement device hardware

The design principles of the measurement station were mainly focused on modularity. It was imperative to design a measurement station that used as many off the shelf parts as possible with minimal custom part design required. As such, when designing the station itself, four main modules were decided to be included. The modules are as follows.

- Main computational module.
- Microphone module.
- Environmental sensing module.
- Power delivery module.

Within the bounds of the modular system two modules were decided to be connected within a single sensory assembly. Those were the microphone and environmental sensing modules. Otherwise, all of the station's systems are completely interchangeable with equivalent types of hardware.

To ensure the modifiability and to allow for sufficient computational capacity of the base measurement device, a Raspberry Pi 4B single-board computer was chosen as the base computing module of the measurement station. This allows the use of the I²S and I²C protocols for communication with both the microphone and the environment probe. The single board computer also provides power conversion for low-voltage modules and an operating system for the software to execute within.

Many types of microphones were under consideration when designing the measurement station. Finally, the microphones used were consumer-grade MEMS microphones mounted on a prototyping PCB board. The microphones were SPH0645LM4H produced by Knowles and integrated by Adafruit into the Adafruit 3421 breakout board. The microphones declare a sensitivity of -26 dBFS and a signal to noise ratio of 65 dB(A). The microphone was connected to the measurement system via the I²S protocol.

Two main environmental probes were considered when designing the environmental sensing module. The contenders were the DHT 22 temperature and humidity sensor, and the BME 280 temperature, humidity, and atmospheric pressure sensor. The DHT 22 module proved to be too large to reliably fit within the enclosure chosen for the project, as such the BME 280 sensor was chosen. It interfaces with the main compute unit of the station via the I²C protocol.

A final choice was made when it came to the power backup of the measurement station. A design constraint was established, that the measurement station is required to withstand a 120-minute power outage event without stopping the monitoring. It was quickly established that the most resource efficient way to do this was to utilise a UPS hat available for the Raspberry Pi 4B and modify it to use a larger energy cell. The Waveshare Li-Ion Battery HAT was used and modified to accommodate the larger size of 18650 battery cells. The final battery cells used were Sony US18650VTC4 2100 mAh Li-Ion cells, which would provide adequate two-hour battery backup for an expected maximum load of 1 A.

Many assembly parts needed to be 3D printed, and were designed for ease of print, with emphasis on the ease of assembly of the measurement station. An important part of the assembly is the microphone windshield which is a fully custom-made assembly consisting of two parts, between which an audio-grade microphone protective foam is placed before screwing the part into the main assembly.

The whole hardware of the measurement device can be seen in Figure 1. Assembly of a single measurement station was measured

to be around 90 minutes using simple tools. Printing of the 3D printed parts was not included in the assembly time.

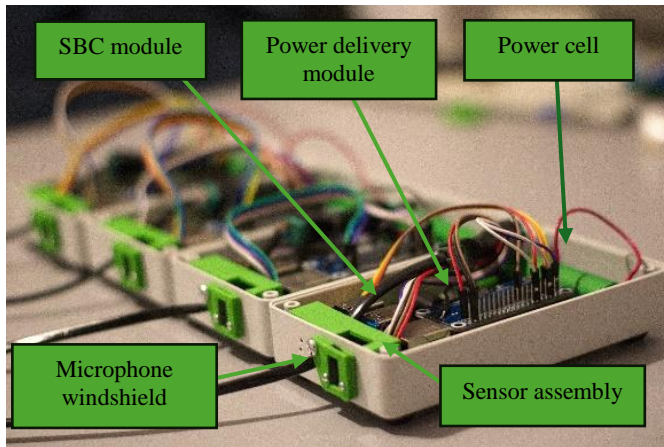

Figure 1. All four measurement stations made for the project with modules shown.

3. Software solutions and networking

The measurement station base operating system is the Raspberry Pi Bullseye OS with a kernel version of 6.1. This legacy version of the system was chosen due to compatibility concerns with drivers for older devices. The operating system was set up in text-only mode. Within the operating system, an Adafruit-provided driver was installed to allow for the interfacing of the MEMS I²C microphone with ALSA. The driver provides a simplified audio device software interface, that is nonetheless enough to use the higher-level API provided by the PortAudio package to interface with measurement scripts.

The software solution used within the measurement station is as modular as the hardware it runs on. It is split into multiple modules, which are independent from each other by design and interface only via a central overseer thread that launches appropriate module threads at appropriate points in time. It should be noted that due to the structure of the software it is easy to implement different monitoring methods, and even new measurement threads. This allows the software implementation to act as a base for future modifiable projects.

The overseer thread launches a measurement thread at the start of every full minute, which then opens a device handle and performs acoustic measurements for a full minute, after the measurement is completed, the results are appended to a file stored in a configurable location. The threads overlap in their execution in such a way that continuous monitoring is performed. The overseer launches the communication and parameter calculation thread every minute at exactly half a minute after the measurement thread begins and reads previously saved results from a file on disk. The thread then calculates the desired parameters and publishes them both to another file on disk with a configurable location and to a central server via the MQTT protocol.

All file operations are safeguarded from race conditions and conflicts in file handling. The system overall is designed in a fail-safe manner, meaning that even if a thread was to come across an unhandled exception and stop unexpectedly, the event would be logged, and another thread will start on the next measurement period. Many of those features are user-configurable and do not require a change in code to modify.

To ensure a great compatibility and accessibility to collected data across many platforms, a REST API was created. Its main function is to be a connector for measurement stations, the database and applications that use the data – mostly done via multiple endpoints. The API was created in .NET 6.0 and uses frameworks like ASP.NET Core, Entity Framework. Due to the selected approach of a code architecture, it is easy to expand and add new functionalities.

The currently selected way of utilizing the API is through a website made in Blazor, which also uses some open-source components, mainly for the user interface. The website provides features to monitor and analyse the data. The main two are a map and a variety of charts. It allows a user to watch real-time levels of noise measured by stations.

4. Measurement accuracy validation

The main purpose of the base station is to provide accurate sound pressure level measurements. To this end, the module was calibrated using the anechoic chamber at AGH UST Technical Acoustics Laboratory. Measurements were performed according to the reference microphone method of measuring the frequency characteristics of the measurement set-up. The method used was inspired by the IEC 61094-3:2016 standard [9].

First, a recording was made using the reference microphone with a known, validated frequency response. The microphone used was a Gras 46AE measurement microphone and pre-amplifier set. The microphone was then connected to the Gras 12AX signal conditioner, and then finally to the USI U24XL audio interface. The speaker used in the measurement session was a Genelec 8040BPM studio monitor. The measurement set-up is shown in Figure 2. The distance between the speaker and the microphone was 2 m.

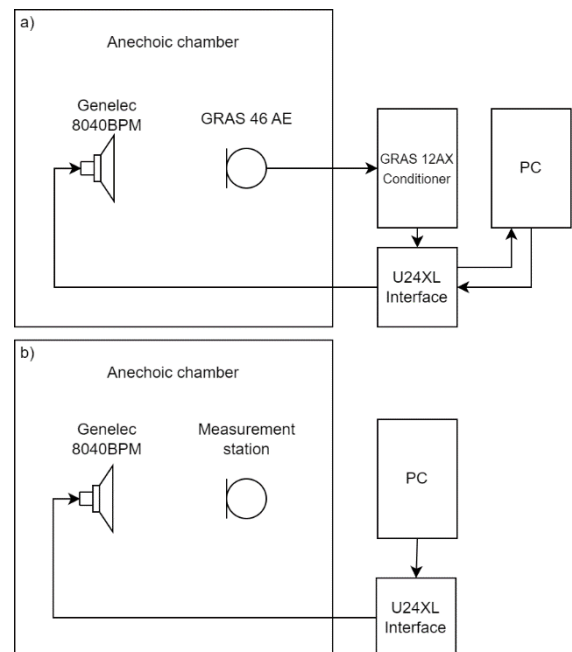

Figure 2. Measurement set up for determining free-field microphone characteristics, a) Reference microphone b) Test scenario with the measurement station.

After performing measurements with the reference microphone, the measurement station was placed in the same spot, as can be seen in Figure 3. The measurement station was positioned so that the microphone of the station was exactly at the same distance from the speaker as the reference microphone capsule was. Measurements were performed by both recording the raw audio data and the sound power levels reported by the measurement station.



Figure 3. Measurement station positioned within the anechoic chamber.

The resulting frequency response curve of the monitoring station can be seen in Figure 4. It can be seen that the frequency response of the measurement set-up is not flat, and shows around 6 dB of gain around 2000 Hz, which then stays consistent up to 20 kHz. This is to be expected of a low-cost microphone and was accounted for in the sound pressure level processing. When looking at total A-weighted levels, the absolute error between the reference microphone and the measurement station sound pressure level was established to be -2.3 dB. The calculated error value is the calibration coefficient of this microphone set-up and was put into the configuration file for the station. The noise floor of the microphone was also measured by leaving the station within the anechoic chamber and performing measurements. The measured noise floor of the microphone is 26.1 dB(A).

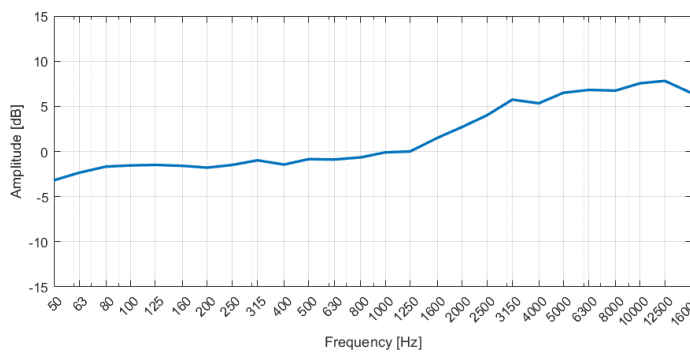

Figure 4. Frequency response curve of the tested device. A sharp rise in the response can be seen around 2000 Hz.

5. Test rollout

After calibrating measurement stations, a test rollout of the system was performed. In total, three stations were placed in the environment around Krakow. One was located at AGH University D1 building, outside the laboratory window. The other two were situated outside the windows of private apartments and connected to the wi-fi networks available at the measurement site. Test locations of microphones can be seen in Figure 5.



Figure 5. Station mounted outside a private apartment (top). Station mounted at AGH D1 building (bottom).

The test was carried out through the weekend, with the stations performing continuous measurements and sending the results to the MQTT broker, which passed data onto the central server being tested at the same time. After the weekend-long stress test, a long-term test was carried out on the station at AGH. The test was concluded after two months, due to the extreme cold conditions, which caused the power delivery chip to malfunction. This, despite the hardware failure is a positive result of the test, as the main goal of the long-term test was to establish the effective operating conditions of the station. The temperature at the moment of failure recorded by the station was around -10°.

6. Summary and future potential

The goal of this work was to develop an open, easily modifiable in both hardware and software measurement station that could monitor sound pressure levels both within rooms and in the environment. The system was to utilise off the shelf parts with minimal 3D printing or machining required and was to provide a codebase that would be modular and easy to expand upon.

Future work with this project may also include a fuller exploration of the Raspberry Pi's computing capabilities. The stations may be used, for example, as a base to develop a deep learning based distributed early fault detection system for large-scale industrial plant monitoring, the need for which is evidenced by the impact such systems make both in industry and science [10]. With the reduced cost per station and relatively high compute ability there are many possibilities to explore in the future.

References

- [1] Stansfeld Stephen, Haines Mary, and Brown Bernadette, "Noise and Health in the Urban Environment," vol. 15, no. 1-2, pp. 43-82, 2000, doi: doi:10.1515/REVEH.2000.15.1-2.43.
- [2] J. Hegewald *et al.*, "Traffic Noise and Mental Health: A Systematic Review and Meta-Analysis," *Int J Environ Res Public Health*, vol. 17, no. 17, 2020, doi: 10.3390/ijerph17176175.
- [3] S. Kephelopoulos, M. Paviotti, F. Anfosso-Lédée, D. Van Maercke, S. Shilton, and N. Jones, "Advances in the development of common noise assessment methods in Europe: The CNOSSOS-EU framework for strategic environmental noise mapping," *Science of The Total Environment*, vol. 482-483, pp. 400-410, 2014, doi: <https://doi.org/10.1016/j.scitotenv.2014.02.031>.
- [4] "Airly network webpage," <https://airly.org/en/>.
- [5] M. Banach, R. Długosz, J. Pauk, and T. Talaška, "Hardware Efficient Solutions for Wireless Air Pollution Sensors Dedicated to Dense Urban Areas," *Remote Sens (Basel)*, vol. 12, no. 5, 2020, doi: 10.3390/rs12050776.
- [6] "IEC 61672-1:2013 Electroacoustics - Sound level meters - Part 1: Specifications," *International Electrotechnical Commission*. 2013.
- [7] C. Mydlarz, J. Salamon, and J. P. Bello, "The implementation of low-cost urban acoustic monitoring devices," *Applied Acoustics*, vol. 117, pp. 207-218, 2017, doi: <https://doi.org/10.1016/j.apacoust.2016.06.010>.
- [8] D. Grimaldi and M. Marinov, "Distributed measurement systems," *Measurement*, vol. 30, no. 4, pp. 279-287, 2001, doi: [https://doi.org/10.1016/S0263-2241\(01\)00019-7](https://doi.org/10.1016/S0263-2241(01)00019-7).
- [9] "IEC 61094-8:2012 Measurement microphones - Part 8: Methods for determining the free-field sensitivity of working standard microphones by comparison," *International Electrotechnical Commission*. International Electrotechnical Commission, 2012.
- [10] A. Qurthobi, R. Maskeliūnas, and R. Damaševičius, "Detection of Mechanical Failures in Industrial Machines Using Overlapping Acoustic Anomalies: A Systematic Literature Review," *Sensors*, vol. 22, no. 10, p. 3888, May 2022, doi: 10.3390/s22103888.