

UNIT ENGINEERING OF SOLID MATERIALS COMPLEX POWDER PRODUCTION BY HIGH-SPEED PROCESS.

РАЗРАБОТКА УСТАНОВКИ ДЛЯ ПОЛУЧЕНИЯ МНОГОКОМПОНЕНТНОГО ПОРОШКА ТВЕРДЫХ МАТЕРИАЛОВ, ВЫСОКОСКОРОСТНЫМ СПОСОБОМ.

Titov Y., Rechenko D., Tsarenko I., Petrov I.
Omsk State Technical University - Omsk, Russia

At the present time, one of the main directions of mechanical engineering technology comes updating of existing and engineering of new non-waste, material-saving production processes, i.e. such processes that provide preforming with minimum allowance or without them for the next machining with reducing of expenses on scarce materials. Powder metallurgy has certain role in this problem solution.

At present, powder metallurgy in general and producing of powder of small dispersivity in particular find big application in many different areas. Specific interest to nano- and ultra-disperse powders is connected to their application as a feedstock for production of ceramic, magnetic and composite materials, superconductors, solar batteries, filters, and additives to lubricating stuff, high-impact solder alloy components, feedstock for 3D printers and any others.

Methods of nano- and ultra-disperse materials process are divided into physical, chemical, biological and mechanical, i.e. nature of receipt of materials process is in base of this classification. [1]

Main and most common type of mechanical powder production is grinding with the use of mill. There are many grinding mills in different modifications. Their construction depends on production type and customer's demand, but all of them work under the same principles. Relatively big material elements travel around revolvable cylindrical vessel all the time, they communicate with grinding balls, and as a result these elements are grinded up to finely-divided range. [2,3].

Benefits of mechanical grinding approaches are:

- 1) Comparative easiness of installation and technologies;
- 2) Ability of grinding of different materials;
- 3) Ability of producing powders from alloys;
- 4) Ability of producing materials in great numbers.

Disadvantages of mechanical method:

- 1) Probability of grinding powder polluting by cutting agent;
- 2) Difficulties of producing powders with narrow particle size distribution;
- 3) Product contents regulation difficulties during grinding process;
- 4) Mill flow differs in energy intensity and cost [4].

Analyzed benefits and drawbacks of this approach, there is suggested high-speed approach of producing of ultra-disperse powder. Patented machine is engineered on the base of special tool and cutter grinding machine, semiautomatic VZ-326F4 with computer numerical control (CNC) [5].

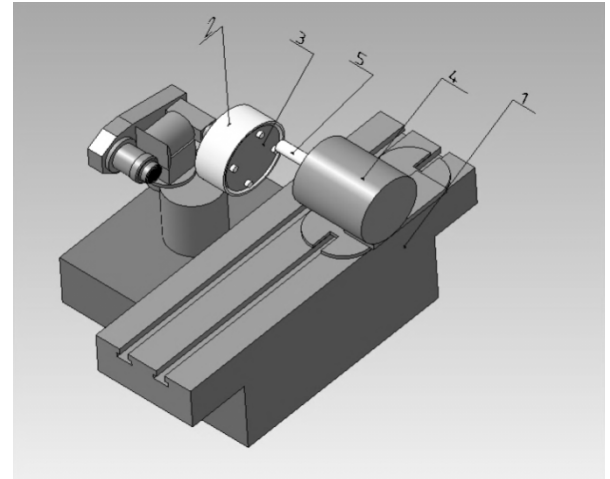

Fig.1.3D-model of machine for producing powder by high-speed process (1 – frame; 2 – gathering case ; 3 – grinding blade; 4 – feeding device; 5 – raw stock).

This machine represents comparatively new mechanical approach of powder process from solid materials, where material grinding, in the form of cylindrical work, is completed with the help of grinding blade with an abrasant (grinding) wheel [6,7].

The machine is modernized for high-speed method of ultra-disperse powder producing. Modernization involved installation of CNC system and new head for high-speed processing. Domestic CNC system "Mayak-600" was installed on this machine. Application of this system lets work the stock in automatic mode, setting the process once a shift, and then just setting new material. Also, the standard grinding head was changed to the head meant for high-speed processing. Special antifriction bearing and seamless band were applied. After modernization, the machine provides spindle rpm up to 30000 rpm.

Mean particle size of produced powder ranges from 100 nm to 800 nm. (fig.2).

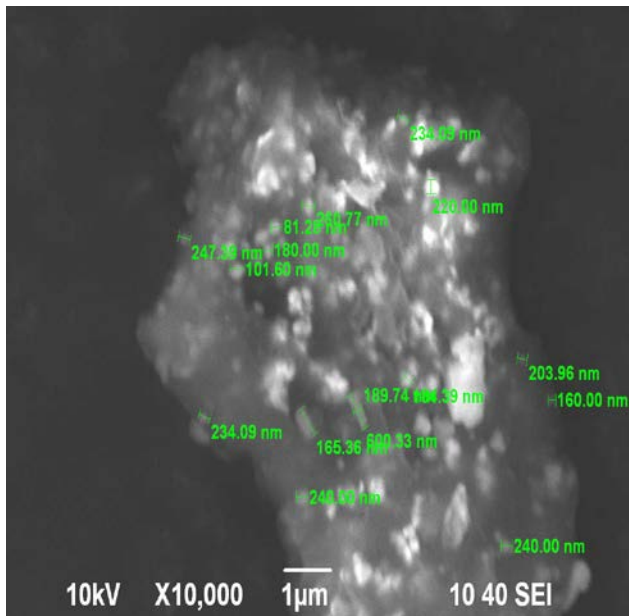

Fig.2. Powder of multicomponent neodymium magnet produced by high-speed method.

Represented method provides ultra-disperse powder producing from any solid material, including multicomponent. There is, also, reducing of producing particles' dimensional variation and making it possible to produce particles of less than 800 nm. Adding of liquid nitrogen reduces probability of high temperatures that appears while grinding on high-speeds; consequently, there is no possibility of fire risk in this process. Besides, nano-powders produce in liquid nitrogen environment are covered with thin surface oxynitride film, thereby they keep increased resistance to sintering and save particles size while heating up to 900-950⁰C. [8]

References

1. A. s. 1112655 (USSR). Metal powder producing approach / Davydovich V., Yavorovskiy N., Lerner M., Krysin S. – 1984.
2. Powder metallurgy. Materials, technology, characteristics, application area: reference book /I. Fedorchenko [and others]; editor in chief I. Fedorchenko. – Kiev: Naukova Dumka, 1985. – 624 p.
3. Davydovich V. Metal powder producing approach: a.s.USSR № 1112655, IQR V2269/24, from 10.12.81. - / Metal powder producing approach / Davydovich V., Yavorovskiy N., Lerner M., Krysin S.
4. Lerner M. Dependence of metals' nano-powders disperivity and their sintering process from gas atmosphere temperature while electric conductor explosion / Lerner M., Davydovich V., Svarovskaya N. // Physical mesomechanics. – 2004. – № 7; P. 2. – P. 340–343.
5. Pat. 030364 Russian Federation, IPC B22F 9/00 Machine for producing metal powders. / D. Rechenko, A. Popov, Yu. Titov, K. Gosina, R. Kamenov; applicant and patent holder Omsk State Technical University. - № 201411922922; pend. 13.05.14 ;

6. Pat. 55665 Russian Federation, IPC B24D 17/00. Grinding wheel for diamond-abrasive processing / D. Rechenko, Yu. Nurtudinov, A. Popov; applicant and patent holder Omsk State Technical University – № 2006111080/22;pend. 05.04.06; published. 27.08.06. Bulletin. № 24. – 2 p.: fig.
7. GOST 2447-82 Grinding heads. Technical regulations. Moscow; Standard, 1980. – 12 p.
8. Kisel A., Rechenko D., Popov A.Y, Titov V. Producing of ultra-disperse powder with mechanic method using liquid nitrogen/NANOTECHNICS. - №1 (37). – 2014. - P. 73-74.