

INVESTIGATION OF THE TRIBOLOGICAL CHARACTERISTICS OF THE STAINLESS STEEL X20Cr13

Prof. dr. sc. Marušić V.¹, Opačak I., mag.ing.mech.¹, Prof. dr. sc. Nedić B.², mr. Jovanović D.³, dr. sc. Rozing G.⁴
 Faculty of Mechanical Engineering, University of Osijek, Trg Ivane Brlić-Mažuranić 2, Slavonski Brod, Croatia¹
 Faculty of Mechanical Engineering, University of Kragujevac, Sestre Janjić 6, Kragujevac, Serbia²
 Zastava Arms Inc, Kosovska 4, Kragujevac, Serbia³
 Faculty of Electrical Engineering, University of Osijek, Kneza Trpimira 2B, Osijek, Croatia⁴

vmarusic@sfsb.hr, iopacak@sfsb.hr, nedic@kg.ac.rs, j.desimir@gmail.com, goran.rozing@etfos.hr

Abstract: For the purposes of testing tribological characteristics of the stainless steel X20Cr13 designed for the parts of process industry plants for the production of sunflower oil, test samples were made and heat treatment by improving on different hardnesses was performed. Final machine processing of the samples was performed out by grinding and polishing. This way, the different characteristics of the surface layer and the different surface topography were achieved. The paper presents the results of the impact of the hardness on characteristics of the stainless steel X20Cr13. By examining the resistance to the adhesion wear it was concluded that the higher wear was on the test samples which have been in the raw condition and who were also loaded by higher forces. Therefore, the quality of the surface wear greatly affects the surface roughness and the coefficient of friction.

Keywords: STEEL X20Cr13, TRIBOLOGY, ADHESION WEAR, TOPOGRAPHY, COEFFICIENT OF FRICTION

1. Introduction

Tribology is not a science „for the sake of science“. Tribology is scientific approach by extending and solving problems of parts which are exposed to wear. The aim is to reduce costs and losses of tribological nature [1]. The paper presents the results of the impact of topography surface and coefficient of friction on the characteristics of the stainless steel X20Cr13. Steel X20Cr13 is the martensitic stainless steel resistant to water and water vapor and the organic acids. It is widely used in making surgical instruments and household accessories, to the creation of machine parts such as eg. shafts, turbine blades, etc. [2]. The equipment for testing tribological characteristics were examined for resistance to adhesion wear of the test samples. For the purposes of the testing „block on the disc“ method was used. When examining the lower sample (disc) is rotated and the sample has on the top (block), which is loaded by a certain force. Mutual contact of the test samples is performed by the peripheral surface of the lower sample (disc) and the lower surface of the upper sample (block) [3]. The aim is to analyze the change of surface roughness, the coefficient of friction and quality in terms of wear surface of the test samples.

2. Equipment for investigation of the tribological characteristics

Tests of the tribological characteristics of the stainless steel X20Cr13 were conducted on improved and computer supported tribometer TR-95 in contact „block on the disc“ (Figure 1) at the Faculty of Engineering, University of Kragujevac.

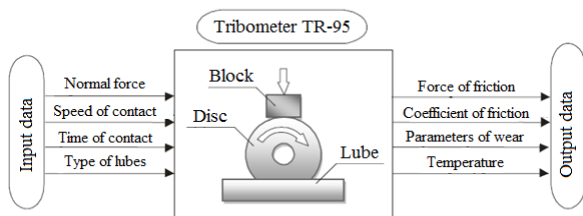

Fig. 1 Input and output data of tribometer TR-95 [4].

Tribometer TR-95 allows varying conditions of contact in terms of shape, dimensions and materials of contact elements, the normal contact load and speed skating. Tests can be performed in conditions with lubrication and without lubrication. The basic configuration of the tribometer consists of: a drive system, system load, the system for managing, lubrication system, the system of self-adjusting blocks and measuring system, Figure 2.

The drive system consists of an electrical motor with pulleys, belts and variator that allows varying of the speed from 100 to 1200 r/min. There is a rotational disc on the main shaft. The system of loads by weight or steam allows load from 0 to 500 N.



Fig. 2 Tribometer TR-95 [4].

The system for managing is realized by means of linear rolling bearings, in which stress is eliminated backlash. Lubrication system consists of a variety of containers for lubricant or the system for the supply of lubricating oil in the contact zone. The system of self-adjusting block and drive has a duty to at all times ensure the transfer of the normal load in the direction of the axis of the disc and contact throughout the length of the block on the disc. This system realized the construction of a special rotating carrier of the block, Figure 3.



Fig. 3 Carrier of the block [4].

3. Experimental investigations

Tests samples in the form of discs dimensions $\phi 35 \times 6,3$ mm and blocks dimensions $6,3 \times 15 \times 10$ mm, made of stainless steel X20Cr13 (according to AISI 420). Declared and tested the chemical composition of steel is shown in Table 1.

Table 1: Chemical composition of the steel X20Cr13 [5].

	Chemical composition, %					
	C	Cr	Mn	P	S	Si
Declared	0,16 ÷ 0,25	12 ÷ 14	max. 1,5	max. 0,040	max. 0,015	max. 1,0
Tested	0,21	12,8	0,6	0,031	0,013	0,67

After test samples were made heat treatment by improving on the different hardnesses was performed. Hardened test samples are arranged in pairs so that a disc and a block in mutual contact consisted a tribometrical pair, Figure 4.

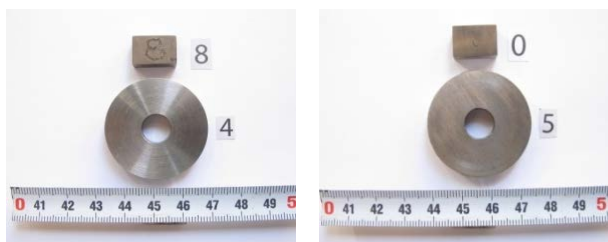

Fig. 4 Representation of the tribometrical pairs.

A total of nine tests for resistance to adhesive wear and investigation plan is presented in Table 2.

Table 2: The investigation plan of the samples on the tribometer TR-95.

Investigation	Disc	Block	Force, N	Speed, m/s	Duration, h
T1	1 ^S	5 ^K	100	1	1
T2	2 ^S	3 ^S	100	1	1
T3	3 ^S	11 ^K	50	1	1
T4	4 ^S	8 ^K	100	1	1
T5	5 ^K	0 ^K	300	1	1
T6	7 ^K	1 ^S	300	1	1
T7	12 ^K	7 ^K	200	1	1
T8	13 ^K	10 ^K	200	1	1
T9	14 ^K	12 ^K	50	1	1

* K – tempered condition, S – raw delivery condition.

3.1. Investigation of resistance to the adhesion wear

Test of resistance to the adhesion wear of the samples was performed on tribometer TR-95 in contact „block on the disc“, Figure 5.

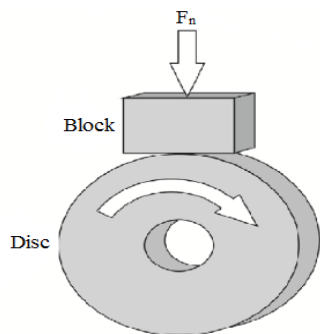
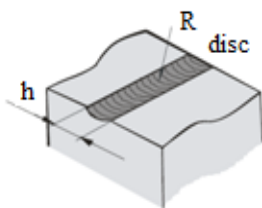

Fig. 5 Sketch of the method „block on the disc“ [4].

Each individual test lasted one hour. The investigation was conducted with lubricated sunflower oil where the samples of discs were partially submerged. Blocks are placed on the discs and their mutual contact came to the appearance of the adhesive wear. Speed of disc was 1 m/s, or 554 r/min. After testing the blocks, traces of wear were analyzed, Table 3.

Table 3: Value width of the traces of wear blocks and coefficient of friction.

Block	Width of the traces of wear, mm	Coefficient of friction
5	1,775	0,024
3	1,088	0,008
11	0,678	0,012
8	1,868	0,023
0	7,478	0,13
1	6,015	0,08
7	4,256	0,068
10	4,461	0,068
12	0,669	0,014



Test samples for testing resistance to the adhesion wear are loaded by forces from 50 to 300 N. It is important to highlight the fact that in two tests, test samples during wear did not withstand the power load of 100 N so the referred tests were performed with a load force of 50 N, tests T3 and T9 in Table 2.

Table 3 shows that the higher wear of the block came with the load forces from 200 to 300 N, while less affected were blocks which were loaded by forces from 50 to 100 N. Also in these blocks is not observed a large difference in the widths of traces of wear, in contrast to the blocks that have been loaded by greater forces. Traces of wear on the blocks was recorded on a light microscope „Leica DM 2500 M“ with different increases, Figure 6.

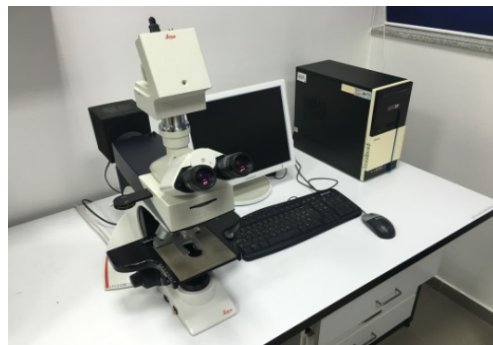

Fig. 6 Microscope „Leica DM 2500 M“.

Traces of wear of the block 8 are shown in Figure 7, while traces of wear of the block 0 are shown in Figure 8.

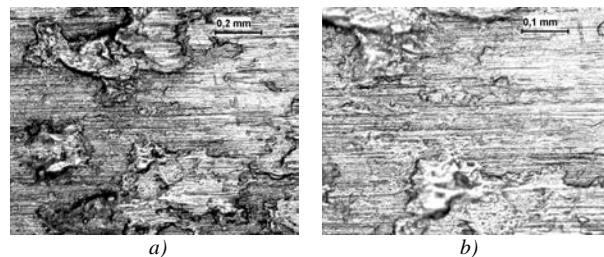

Fig. 7 The characteristic traces of wear of the block 8. a) magn. 100x; b) magn. 200x.

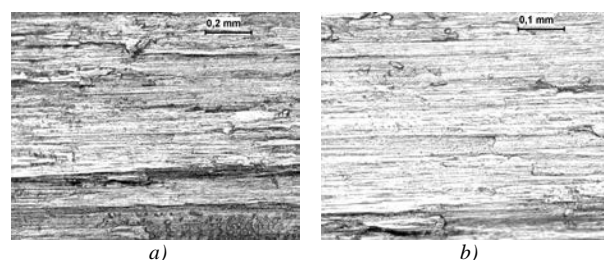

Fig. 8 The characteristic traces of wear of the block 0. a) magn. 100x; b) magn. 200x.

Figures are showing bigger wear of the block 0 compared to the block 8. The reason for this lies in the fact that the block 0 was wasted by disc 5 which has been hardened in a condition with extremely higher hardness compared to the disc 4, which was in the raw delivered condition, from which block 8 was wasted. Also during the wear block 0 was loaded with force of 300 N, unlike the block 8 where the loading force was 100 N.

3.2. Investigation of topography

After the test for resistance to the adhesion wear was performed, the surface topography of test samples was conducted. Heat and final machining obtained different characteristics of the surface layer and the different surface topography of the test samples. Figures 9 and 10 are showing the different topography surface of the disc 4 in the new condition and disc 7 in the condition of the wear. Worn part of the disc and the topography of used parts can be seen.

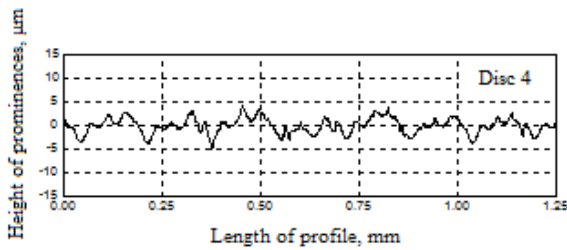

Fig. 9 Representation of topography of the disc 4 in the new condition.

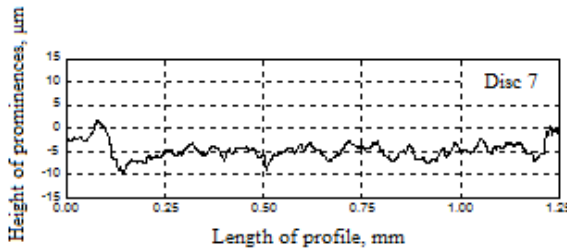

Fig. 10 Representation of topography of the disc 7 in the worn condition.

Figures 11 and 12 are presenting different surface topography in a new block 0 and block 6 in the wasted condition. In place of wear of the blocks width, depth and area of the worn part can be measured.

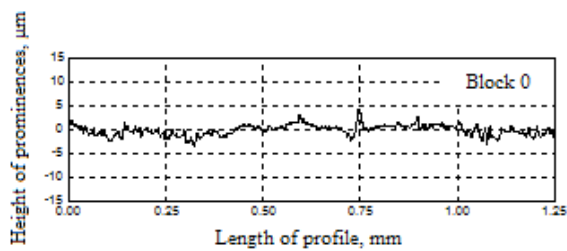

Fig. 11 Representation of topography of the block 0 in the new condition.

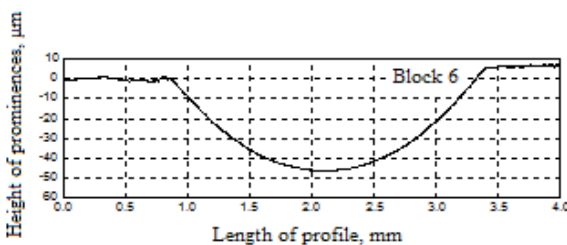

Fig. 12 Representation of topography of the block 6 in the worn condition.

3.3. Investigation the coefficient of friction

In Figures 13 and 14 are shown signals changes in the coefficient of friction during the test period for test T4 and T7.

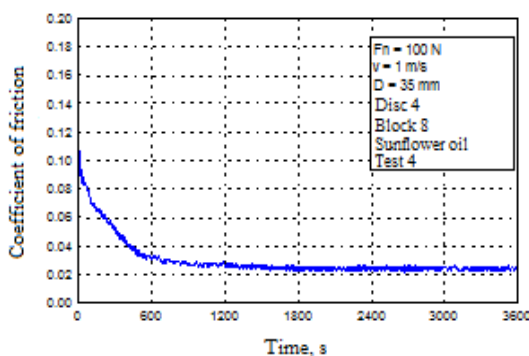

Fig. 13 Value of the coefficient of friction for the investigation T4.

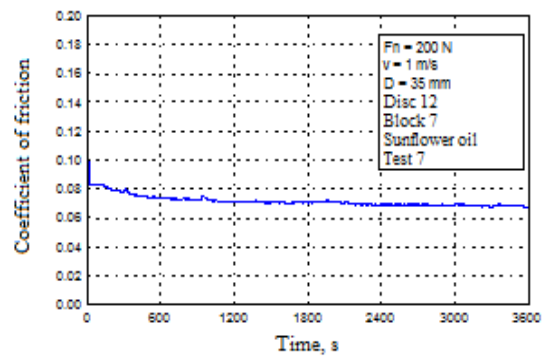

Fig. 14 Value of the coefficient of friction for the investigation T7.

It can be noted initial running period which is lasting up to 15 minutes, and then an approximately constant value of the coefficient of friction. Table 3 shows the mean value of the coefficient of friction after running. It can be concluded that with increased load the coefficient of friction is significantly increased. This because sunflower oil has a poor lubricating characteristics.

3.4. Investigation of hardness

Hardness tests are performed using the method Rockwell (HRC) with a load of 1500 N. Results of measuring the hardness of discs and blocks are shown in Table 4. Hardness of discs that were in the raw or delivered condition is around 25 HRC, while the hardness of hardened discs is around 52 HRC. Hardness of blocks that were in the raw or delivered condition is around 19 HRC, while the hardness of hardened blocks is around 48 HRC.

Table 4: Results of measuring the hardness of discs and blocks.

Disc label	Hardness HRC	Block label	Hardness HRC
Disc 1	25	Block 0	49
Disc 2	25	Block 1	19
Disc 3	27	Block 3	19
Disc 4	26	Block 5	47
Disc 5	53	Block 7	49
Disc 7	53	Block 8	48
Disc 12	50	Block 10	44
Disc 13	52	Block 11	50
Disc 14	52	Block 12	50

4. Analysis of the results and conclusion

The aim of this paper was to analyze the change of surface roughness, the coefficient of friction and quality in terms of wear surface of the test samples. By examining the resistance to the adhesion wear it was concluded that the higher wear was on the test samples which have been in the raw condition and who were also loaded by higher forces. The measured coefficients of friction indicate that increasing the load comes to a significant growth of the coefficient of friction. Therefore, the quality of the surface wear greatly affects the surface roughness and the coefficient of friction.

5. References

- [1] R. Zgaga: *Tribologija u cementnoj i srodnim industrijama*, Zbornik savjetovanja o tribološkoj problematici u cementnoj i srodnim industrijama, Split, 1987.
- [2] M. Novosel, D. Krumes, I. Kladarić: *Željezni materijali - Konstrukcijski čelici*, Strojarski fakultet u Slavonskom Brodu, Slavonski Brod, 2013.
- [3] V. Marušić: *Tribologija u teoriji i praksi*, Strojarski fakultet u Slavonskom Brodu, Slavonski Brod, 2008.
- [4] B. Nedić: *Merna oprema za tribološka ispitivanja*, Monografija (u rukopisu) Mašinskog fakulteta u Kragujevcu, Kragujevac, 2007.
- [5] EN 10088-2-2005: European Steel and Alloy Grades/Numbers.