

# Modeling of Cutting Knife Cylinders in Wet Wipe Machines

Onur Cimen<sup>1\*</sup>, Tahsin Topbaşoğlu<sup>1</sup>, Berkcan Babuz,<sup>1</sup> Oğulcan Söğüt<sup>1</sup>, Yasin Yağız Şimşek<sup>1</sup>, İbrahim Etem Saklakoğlu<sup>2</sup>

KANSAN R&D Center, İzmir, Turkey<sup>1</sup>

Department of Mechanical Engineering, Ege University, Izmir, Turkey<sup>2</sup>

\*onurcimen@kansanmak.com

**Abstract:** One of the most critical consumable expenses in the production of wet wipes is the anvil and knife set used in the cutting unit. Blades that lose their cutting ability over time and become unable to perform their task pose a significant challenge. As wet wipes are essential products for maintaining hygiene and directly affect human health, even the slightest disruptions in production conditions are unacceptable. To ensure the quality and consistency of wet wipe production, it is vital to analyze the factors affecting the strength of cutting blades and implement the necessary precautions. One of the key factors influencing the wear of cutting tools is the mechanical strength of the tool's carrying unit. This paper explores the importance of cutting tools in wet wipe production, the role of mechanical strength in maintaining their effectiveness and application of mathematical modeling to design.

**Keywords:** Wet Wipe Machines, Cutting Knife Design, Modelling of Forces

## 1. Introduction

Cutting tools, such as knives and anvils, are at the heart of the wet wipe production process. These tools are responsible for precisely cutting the wet wipe material into the desired size and shape. When cutting tools wear out or lose their sharpness, they can lead to irregular cuts, frayed edges, or incomplete separation, which in turn affects the quality of the wet wipes.

### Factors Affecting Cutting Knife Design

Several factors contribute to the wear and degradation of cutting blades in wet wipe production:

- Material Properties:** The choice of materials for the cutting tools significantly influences their wear resistance. The material's hardness, toughness, and resistance to corrosion play a crucial role.
- Blade Geometry:** The design and geometry of the blades determine how effectively they interact with the material. Blade angles, bevels, and edge sharpness impact wear.
- Operating Conditions:** The conditions in which cutting tools operate, including cutting speed, pressure, and material properties, affect the rate of wear.
- Environmental Factors:** Environmental factors such as humidity and exposure to chemicals can also influence the wear of cutting blades.

### Mechanical Strength of Carrying Units

One of the crucial factors in the wear resistance of cutting tools is the mechanical strength of the carrying unit. The carrying unit houses the cutting tools and is responsible for applying the necessary pressure and force during the cutting process. If the carrying unit lacks mechanical strength, it can lead to excessive vibration, misalignment, and premature wear of the cutting tools. Therefore, it is essential to design and maintain the carrying unit with robust materials and precise engineering to ensure that the cutting tools perform optimally.

The carrying unit serves as the foundation and support for the cutting tools, playing a pivotal role in maintaining the stability, precision, and efficiency of the cutting process. These are the factors that affect the design of carrying unit:

**Structural Integrity:** The carrying unit must be designed and constructed with structural integrity in mind. It should withstand the repetitive forces and stresses exerted during the cutting operation. Without sufficient structural strength, the carrying unit may deform, flex, or vibrate under the applied loads, leading to misalignment and inconsistent cutting results.

**Alignment and Precision:** Mechanical strength is closely linked to the alignment and precision of the cutting tools. If the carrying unit lacks rigidity, it can result in misalignment of the blades, which, in turn, leads to uneven wear and suboptimal cutting performance. Misalignment not only increases blade wear but also compromises the quality of the final product.

**Vibration Damping:** The mechanical strength of the carrying unit should also incorporate measures to dampen vibrations generated during the cutting process. Excessive vibration can accelerate wear, not only on the blades but also on the carrying unit itself. This can cause premature fatigue, cracking, and deformation of the carrying unit components.

**Material Selection:** The choice of materials for the carrying unit is crucial. High-strength materials, such as hardened steel or aluminum alloys, are often employed to ensure the mechanical strength necessary for consistent and reliable cutting. The selection of materials should consider the specific requirements of the cutting operation and the materials being processed.

**Precision Engineering:** Precision engineering in the design and construction of carrying units is essential. Well-designed carrying units feature accurate machining, tight tolerances, and secure fastenings, all of which contribute to their mechanical strength. These factors are vital for maintaining the alignment of the cutting tools and minimizing wear.

This paper highlights the significance of cutting tools in wet wipe production, discusses the factors that affect their strength, and emphasizes the importance of the mechanical strength of the carrying unit. In order to make a correct design, all the factors mentioned must be taken into consideration. In this study, the analysis of the loads on the carrier unit and the cylinders to which the blades are connected, that affects the strength of the blades used in wet wipe production, was carried out using mathematical modeling techniques.

## 2. Material and methods

Mathematical modeling offers a systematic approach to understanding, analyzing, and optimizing the structural aspects of carrying units and cutting knives. Below are important aspects which should be considered for modeling.

**Finite Element Analysis (FEA) :** Finite Element Analysis is a powerful mathematical modeling technique used in the design of machine units. This method allows to break down complex structures, such as carrying units, into smaller elements and apply mathematical equations to simulate their behavior under different loads.

**Material Properties Optimization:** One of the most important things is to simulate and analyze the effects of different materials, including their elasticity, tensile strength, and fatigue resistance, to determine the most suitable materials for carrying unit components.

**Dynamic Simulation:** Assess the response of carrying units to dynamic forces during the cutting process is possible with dynamic simulations. This includes evaluating the effects of rapid acceleration, deceleration, and vibrations on the carrying unit's mechanical strength.

**Stress and Strain Analysis:** To analyze how different loads and forces affect the structural integrity of carrying unit components is one of the key desing parameters. By performing detailed stress and strain analysis, it is possible to optimize the design and enhance the mechanical strength of cutting knives.

**Optimizing Geometry:** With the help of mathematical algorithms and simulations, it is possible to fine-tune the shape and dimensions of carrying unit components to distribute loads more evenly and reduce the risk of wear. This optimization leads to enhanced mechanical strength and longevity.

A widely used tool for all of these purpose is the SolidWorks CosmosWorks, which empowers to gain valuable insights into the behavior and strength of carrying units under various conditions. By utilizing the CosmosWorks, it can be employ advanced mathematical modeling and simulation techniques to ensure the mechanical strength of carrying units in wet wipe production. This software not only facilitates the accurate assessment of structural performance but also allows for design improvements and material selection based on rigorous analysis.

The main aim of this study is to find out the dimensional parameters, like the cylinder dimensions of the carrying unit for cutting knives. which satisfy the strength and stiffness criteria. Further, the crucial parameters are:

- \* Contact stress between the knife and anvil (strength criteria)
- \* Maximum stress in the knife (strength criteria)
- \* Maximum deflection of the clinder (stiffness criteria)

In this study, a finite element model is developed using Solidworks® Cosmosworks package. The CAD geometry is simplified for the application of load and support.

**3. Results and Discussion**

Modeling studies were started by analyzing the contact situations and the forces occurring at the contact moment of cutting knives. Figure 1 shows the distribution of the forces transferred from the motor on the cutting blades and contact angle.

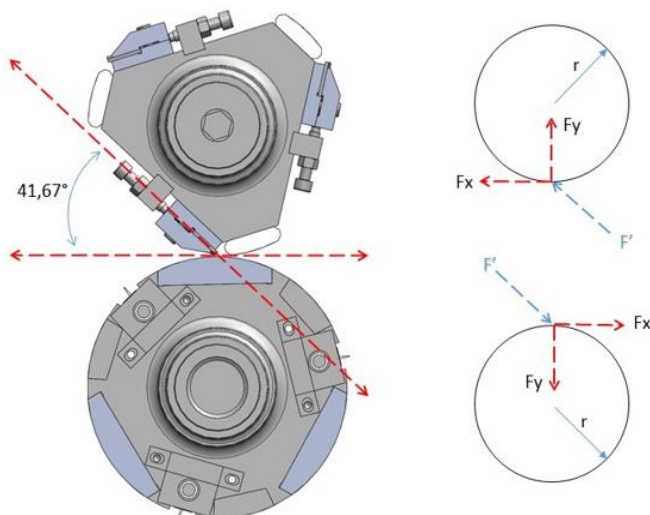

**Figure-1:** Contact angle and forces of cylinder

The cutting forces during the contact was calculated as follows:

$$T(\text{motor}) = 9550 * p / n$$

$$T(\text{motor}) = 9550 * 5 / 2000$$

$$T(\text{motor}) = 23,875 \text{ Nm}$$

$$T(\text{motor,peak}) = T(\text{motor}) * \%300$$

$$T(\text{motor,peak}) = 23,875 * \%300$$

$$T(\text{motor,peak}) = 71,625 \text{ Nm}$$

$$T(\text{reducer,out}) = T(\text{motor,peak}) * \text{ratio}$$

$$T(\text{reducer,out}) = 71,625 * 5$$

$$T(\text{reducer,out}) = 358,125 \text{ Nm} = T \text{ max}$$

$$T \text{ max} = Fx * r$$

$$Fx = T \text{ max} / r$$

$$Fx = 358,125 / 0,120$$

$$Fx = 2984,375 \text{ N}$$

$$F' * \cos \theta = Fx \quad \cos \theta = Fx / F'$$

$$F' * \sin \theta = Fy \quad \sin \theta = Fy / F'$$

$$\cos 41,67^\circ = 2984,375 / F'$$

$$\sin 41,67^\circ = Fy / F'$$

$$Fy = 2656.179 \text{ N}$$

The preparation stages before finite element analyses are shown in Figure 2. The bearing conditions are shown in the first line. The mesh structure is shown in the second line. The third line shows the applied forces. Images of the upper cylinder are given in the first column, and images of the lower cylinder are given in the second column.

	Upper Cutting Roller	Lower Cutting Roller
Fixture (bearing)		
Mesh		
Force		

**Figure-2.** Preparation stages before finite element analyses

The analysis started with the calculation of the deflections that occurred when the current design and AISI 304 SS material were used. According to the results obtained, max deflections were calculated 0,00724 mm which is outside the acceptance limits were observed. The results obtained from the analyses performed using AISI SS material are shown in the Figure 3.

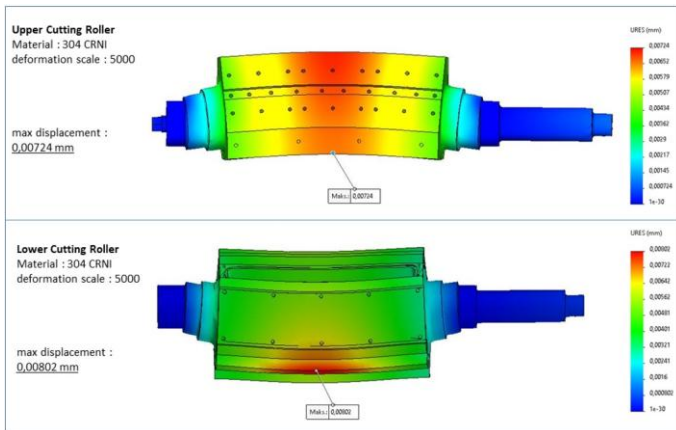

Figure-3. The results obtained from the analyses performed using AISI 304 SS

The design was changed because the results obtained from the first design were outside the target values. In this context, the bearing elements and the carrier shaft diameter have been changed. Additionally, the material used was changed to AISI 316 SS. Visuals of the first and second designs are shown in Figure 4., and the new analysis results made with the material and design change are shown in Figure 5. At the end of the renewed design the maximum deflection value was determined as 0.000881 mm which is acceptable.

	Upper Cutting Roller	Lower Cutting Roller
<b>CURRENT DESIGN</b> Material: 304 CRNI Shaft dia: Ø50mm (*) Bearing: 22216 E (80*140*33)		
<b>NEW DESIGN</b> Material: 316 CRNI Shaft dia: Ø55mm (*) Bearing: 22217 E (80*140*36)		

Figure-4. Visuals of the first and second designs

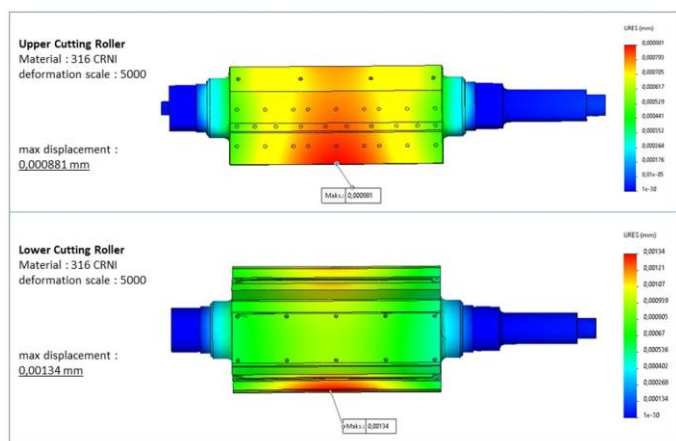

Figure-5. Analysis results made with the material and design change

The general view of the redesigned carrier unit according to the final results obtained is given in Figure 6.

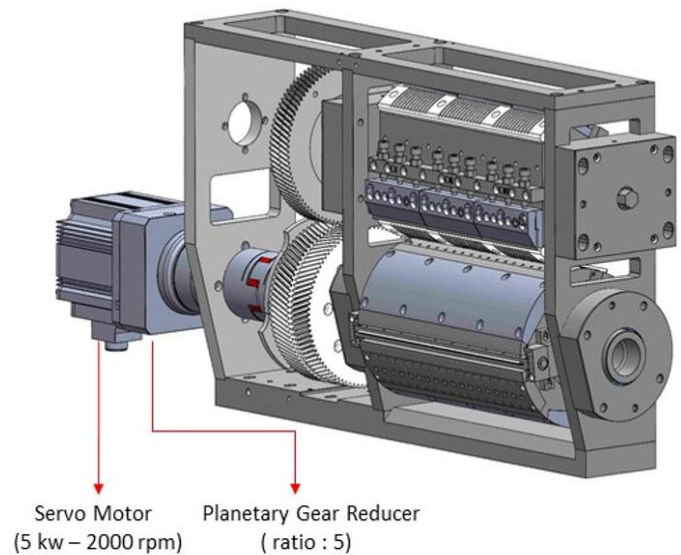

Figure-6. The general view of the redesigned carrier unit

#### 4. Conclusion

In this study, a force analyses that affect the cutting knives carried out using FEA method by SolidWorks CosmosWorks. The analysis started with the calculation of the deflections that occurred when the current design and AISI 304 SS material were used and max deflections were calculated 0,00724 mm which is outside the acceptance limits were observed. The design was changed because the results obtained from the first design were outside the target values. In this context, the bearing elements and the carrier shaft diameter have been changed. Additionally, the material used was changed to AISI 316 SS. At the end of the renewed design the maximum deflection value was determined as 0.000881 mm which is acceptable.

#### 5. References

1. Mathematical Modelling in Solid Mechanics, Editors: dell'Isola, Francesco, Sofonea, Mircea, Steigmann, David (Eds.) ISBN 978-981-10-3764-1, Springer Singapore
2. Mathematical Methods for Physics and Engineering: A Comprehensive Guide, K. F. Riley, M. P. Hobson, S. J. Bence, Cambridge University Press
3. Mechanical Design of Machine Elements and Machines, Jack A. Collins, Henry R. Busby, George H. Staab, John Wiley&Sons, ISBN-13 978-0-470-41303-6
4. Programming the Dynamic Analysis of Structures, Prab Bhatt, CRC Press Published June 13, 2002, ISBN 9780419156109
5. Doyle, J.F. Static and Dynamic Analysis of Structures with An Emphasis on Mechanics and Computer Matrix Methods, ISBN 978-94-011-3420-0, Springer Netherlands
6. Sondipon Adhikari, Structural Dynamic Analysis with Generalized Damping Models: Analysis, ISBN:9781848215214, 2014 by John Wiley & Sons, Inc.
7. Bucalem M.L., Bathe KJ. (2011) Mathematical models used in engineering structural analysis. In: The Mechanics of Solids and Structures - Hierarchical Modeling and the Finite Element Solution. Computational Fluid and Solid Mechanics. Springer, Berlin, Heidelberg
8. A First Course in Finite Elements, Jacob Fish, Ted Belytschko, 978-605-320-607-1