

COMPARATIVE ANALYSIS OF PMAC MOTORS FOR EV AND HEV APPLICATIONS

Velev B.

Institute of Electrochemistry and Energy Systems , Bulgaria

Abstract: In current work is made comparison between the differences in structure methods of propulsion and price of two types of motors with permanent magnets and AC drive (PMAC). PMAC is common name of electric motors - permanent magnets synchronous motor (PMSM) and brushless permanent magnet motor (BLDC). On the basis of comparative studies is selected and tested construction and propulsion of low-cost BLDC motor, suitable for hybrid transmission of HEV.

KEYWORDS: PMAC - Electric motor with permanent magnets and AC propulsion; BLDC - Brushless DC motor with permanent magnets; PMSM - Permanent magnets synchronous motor; EV - Electric vehicles ; HEV- Hybrid electric vehicles; BEMF- Back electromagnetic force.

1. Introduction

The great interest in the implementation of environmentally friendly vehicles require the development and testing of increasingly sophisticated structures traction motors with powerful permanent magnets, the composition of which has exotic rare transition metals (lanthanides). Most frequently in the production of electric cars using synchronous induction motors with permanent magnets (PMSM) [1]. Some companies produce cheaper brushless DC permanent magnet motors (BLDC), suitable for smaller EV / HEV applications [1,3]. Both motors are lightweight, powerful, have regenerative braking system - this is the process by which the motor is used as a generator to refuel the battery when the car stops. These motors are known collectively as the electric motors with permanent magnets and AC drive (electric PMAC) [3]. The main characteristics, advantages and disadvantages are discussed below.

2. Purpose of work

In this work are analyzed and compared the characteristics of the latest PMAC motors used in today's electric (EV) and hybrid vehicles (HEV). Based on the analysis is selected and tested low-cost BLDC motor, suitable for deployment in a hybrid transmission for HEV applications. The work is structured in five parts. The first is a brief analysis of the structure , the basic principles of power and producing the torque of these motors , in the second part we examine the benefits and disadvantages of PMAC Electric and differences between the two species. The third part is devoted to the analysis and testing of selected BLDC motor specifically for HEV application. The fourth part presents experimental studies of selected electric motor and a fifth are locked.

3. Construction and principles for propulsion of PMAC electric motors

There are two basic constructions of the PMAC motor - a structure which is based on the method of mounting of the magnets on the rotor and on the waveform of the back electromagnetic force (BEMF). If the magnets are mounted on the surface of the rotor of the motor, PMAC motor is called a surface-mounted permanent magnets. If the magnets are mounted within the rotor, then the PMAC motor is called internally fitted with permanent magnets. Management trapezoidal waveform BEMF characteristic of BLDC motors, and when the waveform is sinusoidal, the motor is PMSM. The type of construction is either cylindrical (fig.3.1.) Or type "pancake" (fig.3.2.)

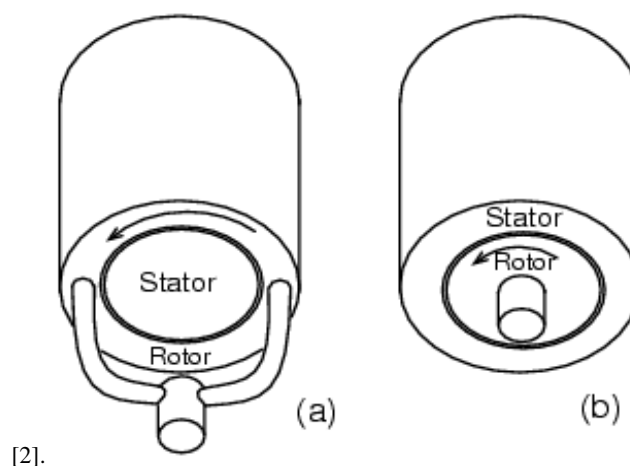

Fig. 3.1. Cylindrical structure PMAC motors
(a) External rotor, (b) internal rotor

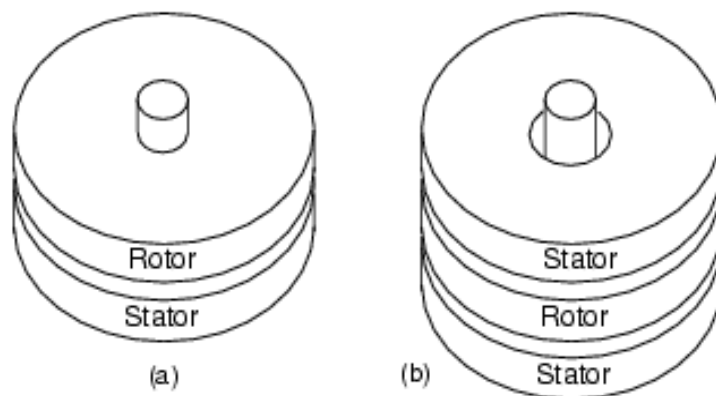

fig.3.2. Construction type "pancake" motors of RMAS
(a) a single stator (b) a double stator

From fig . 3.2 . shows that the highest torque motor must have a "pancake" dual stator - fig.3.2 (b). Engines with a stator on one side of the rotor shown in fig . 3.2 (a) have found wide application in floppy drives on computers. In this type of electric motor , the direction of magnetic flux is axial , i.e. parallel to the axis of rotation . From the above figures it is clear that the structure type "pancake" dual stator shown in fig . 3.2. (B) is the light with the highest torque and therefore is suitable for HEV applications

3.1. Operative principles of drive for PMAC electric motors

One category PMAC motors - BLDC electric motors can be operated with a closed system that is very simple and cheap, because the control variables are readily available at all times

during operation of the motor movement. PMSM electric motor have options to control the drive in open loop, but this control is not as simple and easy as the BLDC and is similar to drive induction motors. For PMSM drives need a advanced control techniques, such as vector control and direct torque control, that makes PMSM motor more expensive [3]. In contrast to PMSM motor which requires constant monitoring of the position of the rotor, BLDC motor with trapezoidal shaped BEMF requires only monitoring every 60 electrical degrees of the period for switching the phase currents. As a result, necessary six switching points per electrical cycle. In general, in each switching point, the switching cycles of change. In this way, it is not necessary to have a position of a sensor with a high resolution as an absolute or incremental encoder or resolver. In this case, a very simple and cheapest (cost <\$ 1) sensor with Hall effect will be enough appropriate. This makes the BLDC motor cheaper than PMSM [4]. During these intervals, switching, however, found waves of torque, creating uneven at low revs and noise during operation of BLDC motor.

3.2. Comparison of torque moment of electric motors PMSM and BLDC

Electric motor BLDC have high torque density at low and medium speed, but is not suitable for continuous operation at high speed, because of its limited capability of weakening the flow. Also, the BLDC trapezoidal shape of the current wave, the torque pulsation is performed in the sixth harmonic of the fundamental frequency. Equations written below show the difference in the density of torque between BLDC and PMSM electric motor in the region of constant torque (PMSM has a dominance in the region, weakening the flow over the motor BLDC). Suppose that I_{ps} and I_p are the peak values of the stator currents in electric motors PMSM and BLDC, respectively, the rms value of these currents are:

$$I_{xv} = \frac{I_{ps}}{\sqrt{2}} \tag{3.1}$$

$$I_d = \frac{I_p \sqrt{2}}{\sqrt{3}} \tag{3.2}$$

Equating the losses in the copper and the substitution of the currents in terms of their peak flow gives:

$$3I_{xy}^2 R_s = 3I_d^2 R_s \tag{3.3}$$

Consequently,

$$I_p = \frac{\sqrt{3}}{2} I_{ps} \tag{3.4}$$

Proportion of torque to the BLDC and PMSM motors is derived from these relationships, as follows:

$$\frac{BLDC}{PMSM} = \frac{(2xE_p x I_p) / \omega}{\left[3x \frac{E_p}{\sqrt{2}} x \frac{I_{ps}}{\sqrt{2}} \right] / \omega} = 1,154 \tag{3.5}$$

The above result indicates that the BLDC motor is about 15.5% more torque than a PMSM in the constant region of the torque. [5] In BLDC under ideal switching, the current is conducted through

120 electrical degrees, with a peak centered BEMF as shown in fig. 3.3. with Hall sensors.

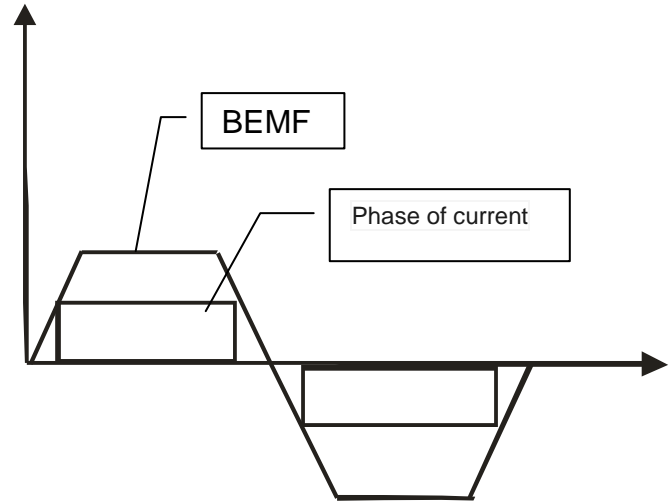

Fig. 3.3. Ideal operation of BLDC motor.

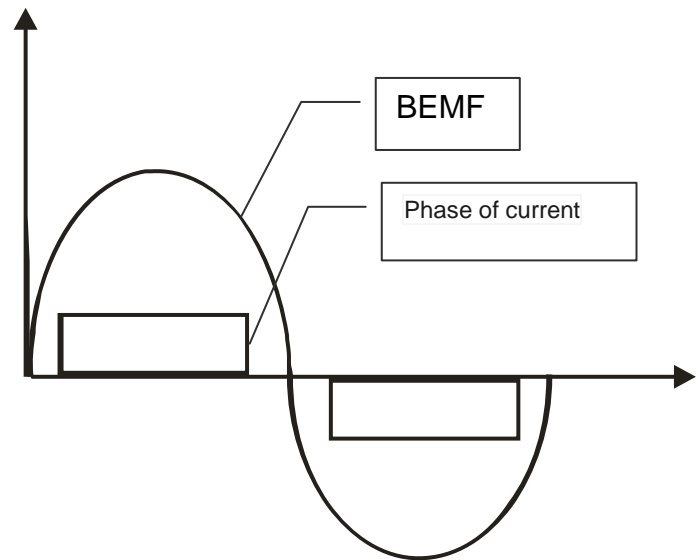

Fig. 3.4. BLDC is controlled like PMSM motor.

BLDC motor may be used as a synchronous motor PMSM as shown in fig. 3.4., but with a complex sinusoidal commutation, for example, with an encoder. [9] Consequently, BLDC is optimized to be managed by the trapezoidal waveform, and is optimized for PMSM control with sinusoidal waveform. BLDC provides commutation electronically and has a closed loop system. Variable frequency of alternating current (AC) drive (inverter) may be used by the same engine PMAC can perform the functions of a BLDC motor in a closed loop (with Hall sensors) and the functions of alternating current AC synchronous motor PMSM in open loop when the engine does not conduct feedback to the controller (for example, when switching is performed with an optical encoder). As a result, if the torque pulsations are not very important, the simple trapezoidal current control scheme (type BLDC), instead of a complex sinusoidal current control scheme (type PMSM), can not be stable, cost-effective and very good solution to control the speed and torque of the engine HEV applications.

4. Advantages and disadvantages of electric motors PMAC

PMAC Compared with conventional motors, PMAC motors have many advantages:

- PMAC electric motors are highly efficient engines. PMSM and BLDC are considered the most efficient of all electric motors. There is a lack of copper coil or a mechanical coupling of the rotor by a collector and brushes. Instead, the permanent magnets of the rotor are used for generating a constant magnetic field of the rotor. These magnets do not consume almost no power, so copper losses are negligible level rotor unlike AC induction and synchronous motors. Also, friction is low and the durability is higher, since no mechanical collector and brushes to wear, in contrast to the direct current brush motors. All these characteristics of electric motors PMAC put them first on the category of high efficiency [6] and makes them very suitable for EV and HEV applications.
- Recent advances in production of permanent magnets with high energy density used in the composition of rare-earth metals, such as in the sintered alloys, samarium-cobalt or neodymium-iron-boron (SmSo; NdFeB), have allowed the achievement of very high magnetic induction motors PMAC . These magnets ensure the provision of high torque and allow the engine to be built smaller and lighter. [6]
- In electric motors PMAC will located in the rotor circuit , which decreases heat and electrical losses. The heat is produced only on the stator , which is more easily cooled by the rotor , because the stator is usually static, and is located on the outer side of the electric motor . [6] PMAC have low maintenance costs, durability and reliability. Brushless and mechanical switches, regular maintenance is significantly reduced and risks such as sparks in explosive or corrosive environments are eliminated. The long life of the motor is based primarily on the quality of the insulation of the windings and bearings (as with other electric motors) , and the lifetime of the magnets [6].
- There is no operating noise generated by switching, because this is achieved electronically rather than mechanically. The switching frequency of the converter when PMSM is sufficiently high so that the harmonics of the noise can not be heard. [6] Because of the trapezoidal waveform of BLDC motors BEMF when there is some noise from the harmonics, but it is very weak and can not be ignored, especially in HEV applications.

PMAC electric motors also have some disadvantages entailed just like any other electrical machines and more specific:

- The cost of permanent magnets is the most important question for both PMAC motor . Permanent magnets rare earth elements such as samarium - cobalt and neodymium - iron -boron are particularly expensive . Magnets neodymium - boron- iron are the most powerful , but also the most expensive. If the initial cost is a major problem in some applications that will be used PMAC motors, then the price of magnets with higher energy density does not allow their use in these applications [6]. For HEV applications the main problem is the compactness and weight of the bike , so electric motors with permanent magnets with high energy density are best suited for these applications .

- Many large opposing magneto-drivers and high temperature can demagnetize the magnets. Although critical of the demagnetization effect is different for each magnetic material should be taken further measures to cool the motor, especially if it is built with compact design (for example, type "pancake") [2,6].
- For surface mounted magnets PMAC motors operate at high speed is limited or not possible due to the mechanical construction of the rotor. The rotor is not suitable to deal with high centrifugal forces at high speed when the magnets are glued on it . This type of installation is not strong enough and does not guarantee the integrity of the magnets , especially in high-speed compact engines. On the other hand , mounted on an internal magnets, the rotors of the PMAC motor are able to move at high speed without a problem in terms of the rotor, because the magnets are mounted within the rotor , but the degaussing is still an important factor in these types of motors [6]
- Since there is a constant energy of the rotor due to permanent magnets , PMAC motors represent a major risk event of a short circuit in winding or damage to the inverter. If a short circuit occurs in the inverter during operation of the motor, the rotor will constantly induced electromotive force in a coil shorted , causing a very large electricity and heat engine. This leads to large reverse torque which tends to block the rotor. For automotive applications , the risk of blocking is not acceptable and must take precautions to protect against short circuit [6]. Fig . 4.1. shows the equivalent circuit for three-phase power transmission from the inverter to the motor PMAC.

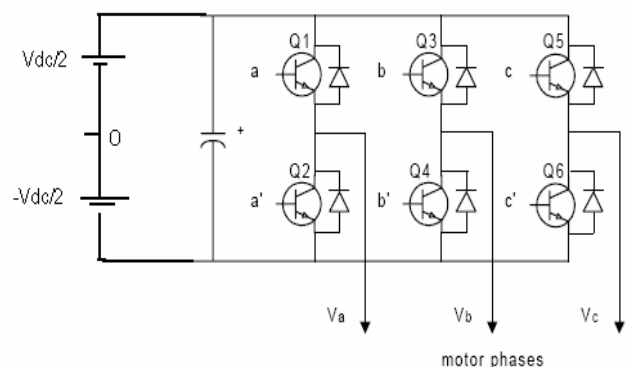

Figure 4.1. Circuit for power transmission with three-phase voltage - inverter (VSI)

The structure of a typical inverter - a three-phase voltage source is shown in fig . 4.1. V_a , V_b and V_c are the output voltages applied to the motor windings . Q1 through Q6 are six power transistors that form the output , which are controlled by one " , b , B ' , c and C ' ' . For AC engine management when the upper transistor switch is turned on, ie , when A, B or C is 1, the corresponding lower transistor is switched off , ie corresponding to "b" or B "is 0.che This means setting the upper line of the switch to turn off and turn on the lower line key and vice versa. exclusion of the states of the upper transistors Q1, Q3 and Q5, or equivalent the states of the A, B and C , are sufficient for an assessment of the output voltage.

5. Selection of brushless electric motor (BLDC) for HEV applications

From the above analysis of the structure, propulsion, advantages and disadvantages of PMAC motors, we conclude that application to power hybrid vehicles in an urban environment, the most appropriate type BLDC motor "pancake" with double stator. We

have selected engine type HPM10KW/120V, production of "Golden motor."

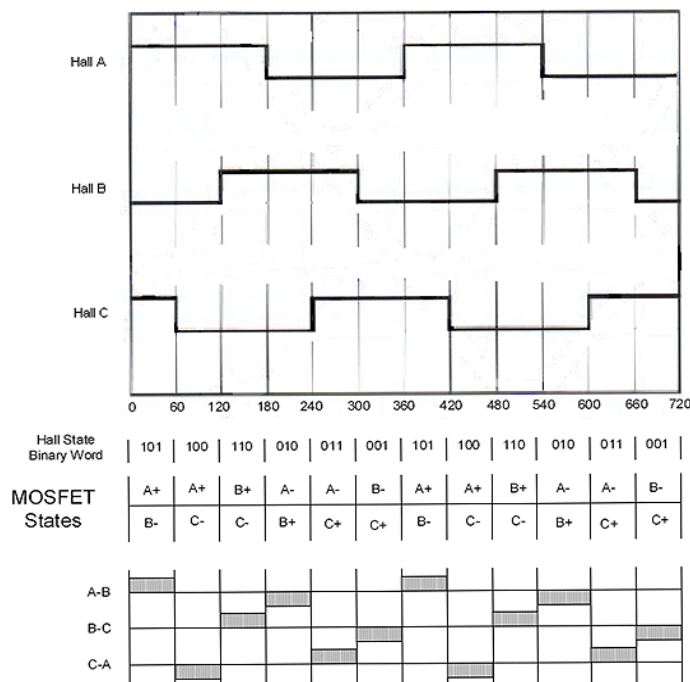

Figure 5.1. Driven by commutation of voltage switching sensors with "Hall" effect .

Each phase BLDC powered by a digital controller in appropriate sequence. Energy is synchronized with the position of the rotor to produce a constant torque, therefore, it is important to know the position of the rotor in order to understand which winding will the Subscriber after energizing sequence. This motor is driven by a system of the Hall sensors as described above, controlling the rotor position [3,4]. For example, in fig. 5.1. Hall-A is aligned with $E_a - E_b$ etc. etc. This means that the output of each sensor with a Hall effect actually leads to a zero crossing of the phase of each BEMF by 30 electrical degrees.

The position information is then used by the controller to decide to activate the inverter switches. Generally, three sensors with Hall effect are used for the three-phase motor (will be referred to as Hall A, B Hall and Hall C., with each 120 ° delay with respect to the previous sensor) to determine the position of the magnetic field of the rotor. When the magnetic poles of rotor pass near sensors with Hall effect, high or low signal is generated when N (North) or S (south) poles pass near the sensors. In general, when the north pole signal corresponds to a "1" and when the south pole of the "0" [5]. Graph of the Hall effect with 120 ° angle sensors divided into operation shown in Figure 5.1. This table represents the state of the high-side and low-side MOSFET transistors of the amplifiers of the half bridge for all three phases during commutation trapezoidal. [4] Sensors rely on speed, position, etc. and send them to the controller that corrects these indications to achieve the desired parameters.

6. Experimental tests of BLDC motor

Experimental verification is carried out on trapezoidal commutation, whether it is possible to control the BLDC motor with trapezoidal commutation sensors using Hall effect. Experimental waveforms of Hall signals as well three in the clockwise (CW), and counterclockwise (CCW) direction of rotation of the motor are shown in Figure 6.1. The rolling direction is viewed on the motor shaft. Series of signals are Hall Hall A-Hall B-Hall C in CW and Hall B-Hall C-Hall A in the direction CCW.

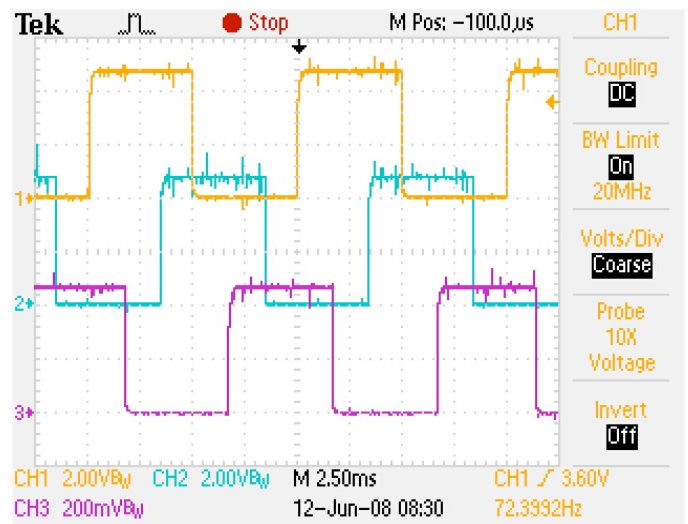

(a) CW direction

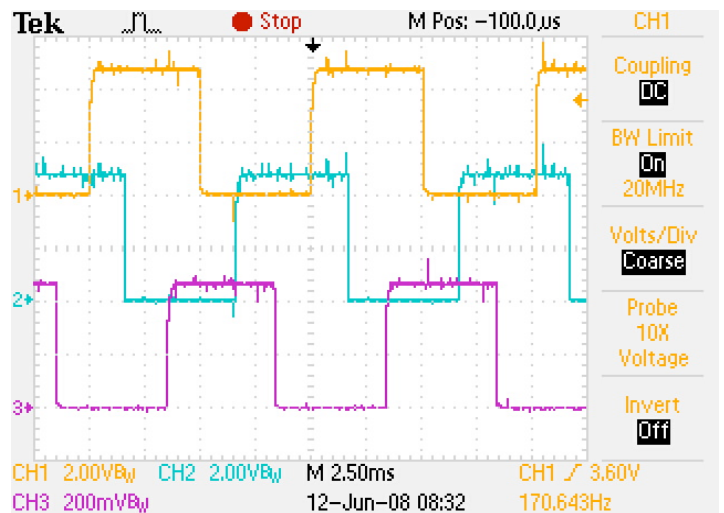

(b) CCW direction

Fig. 6.1. Measured signals Hall in CW and CCW direction of 1500r/min (CH1: Hall A, CH2: Hall B, CH3: Hall C) (Vertical: 2V/div, Time: 5ms/div)

Trapezoidal propulsion based sensors with Hall effect is six steps of current and is shown in Figure 6.2.

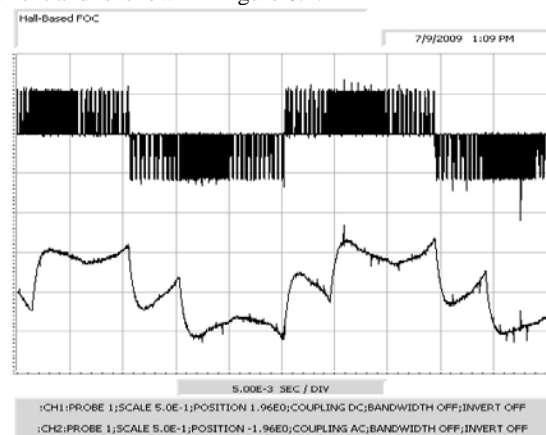

Fig. 6.2. Connection between motor online to line voltage (peak: 25V/div) and line current (bottom: 0.5A/div) six-step commutation

It can be seen that the sensor-based Hall effect trapezoidal drive six-step current, as shown in Figure 6.2. Is not an ideal sinusoid, which results in certain ripple during commutation.

7. Conclusion

Trapezoidal commutation generates rotating waves (pulses) at low speed and relatively effective only in the range of high speeds. However, this method is very popular because of the simplicity of its control algorithm. It uses six successive stages by means of three sensors with Hall effect, in order to obtain information about the position of the rotor. It is very effective in controlling the engine speed, but suffers from a torque ripple during commutation, particularly at low speeds. Therefore, this scheme is the most popular low-budget class applications requiring simple operation and closed loop. The disadvantage is that there is a significant moment of pulses generated by the nonlinearity of the switching, because only two motor windings is current at any given time. Nonlinearities generate noise and vibration. When I used to work at a relatively high speed, 1200 switching provides minimal torque ripple, which is perfectly acceptable for hybrid drive in urban HEV applications.

Literature

1. *Electric motor: Permanent-magnet-motors*, www.britannica.com/ebc/article-45836
2. http://www.allaboutcircuits.com/vol_2/chpt_13/6.html
3. [12]. P.Pillay ad R.Krishnan, "Modeling, Simulation and Analysis of a Permanent Magnet Brushless DC motor drive part II: The brushless DC motor drive," *IEEE Transactions on Industry application*, Vol.25, May/Apr 1989.
4. N. Chaudhary, Al. Mishra, *Hall Effect and Its Application in the Design & Operation of Electronically Controlled Brushless DC Motors*, IJAIEM, Volume 1, Issue 2, October 2012, 201-207 (ISSN 2319 – 4847)
5. P. Pillay, "Modeling simulation and analysis of permanent magnet synchronous and brushless DC motor drives." Ph.D. dissertation, Virginia Polytechnic Institute and State University, Blacksburg, VI, 1987.
6. J. Luukko, "Direct torque control of permanent magnet synchronous machines - analysis and implementation." Ph.D. dissertation, Lappeenranta University of Technology, Lappeenranta , Finland, 2000.
7. P. Yedamale, "Brushless DC (BLDC) Motor Fundamentals," Application Note 885, Microchip Technology Inc., Chandler, AZ, 2003.
8. <http://www.magnelab.com/uploads/4c51d9ba6fe5a.pdf>
9. <http://www.kves.utc.sk/kvesnew/dokumenty/%C5%A1ep/DTC-Ozturk.pdf>