

TRANSITIONS PROCESS OF BULLDOZER, AS A MECHANISM WITH POSITIVE FEED-BACK WITH $K > 1$

Akademician, Ph.D of technical sciences P. Zhunisbekov, Students Ph.D D.Nurzhan, Ph.D G.Skabayeva, A.Kyntugankizi, KazNAU, Almaty, Kazakhstan

Abstract: A bulldozer, like many building, road, agricultural and other machines and mechanisms has a working unit supporting wheels, tracks or skis. All of them have a late feedback in kinematics scheme. In contrast other the bulldozer in kinematics chart has a late feedback with amplification factor of $k > 1$. Thus insignificant change of position of supporting units or shovel, cause a considerable change in the depth of treatment. Number of research works revealed that this transitions period described by an arc, and a circumference.

KEYWORDS: MECHANISM, BULLDOZER, LATE FEEDBACK, TRANSITIONS PROCESS, WORKING UNIT, TRAJECTORY OF KNIFE-BLADE.

Introduction

In the work process operators (bulldozer drivers) very often, sometimes every few seconds, should adjust the shovels (working unit). According to results of the research conducted by us, bulldozers are machines and mechanisms with late feedback and with a coefficient greater than 1. Such mechanisms and machines have closed loops of transfer effects in their kinematic schemes: vertical deflection bearings located behind a working unit is transmitted with a coefficient of more than one back through the frame to the working unit. The transition of effects on the chain bearing-frame-working unit forms a direct bond, and from the working unit through the surface formed by them again to bearing-back. The transition process of bulldozer at a single push is given below. Single push (as a perturbation) due to feedback with more than one coefficient causes further expansion of the roughness formed by vehicle shovel. To eliminate the expansion of roughness the operator intervenes in the course of the transition process, by positive change in the position of shovels. Interference frequency is determined by speed, perturbation size and surface properties of speed and bulldozer bearings.

2. The transition process of the bulldozer as a tool with delayed feedback

Among the reclamation, road construction and agricultural machinery, tools and separate mechanisms there are those in which different supports (wheels, compactors, skis, heels, etc.) are located in the working units and move on surfaces generated by these working units during of technological processes performance. Such machines are bulldozers, which have wheel 1 (Figure 1a) or crawler 1 (Figure 1, b) moving the surface formed by the working units - with blade 2.

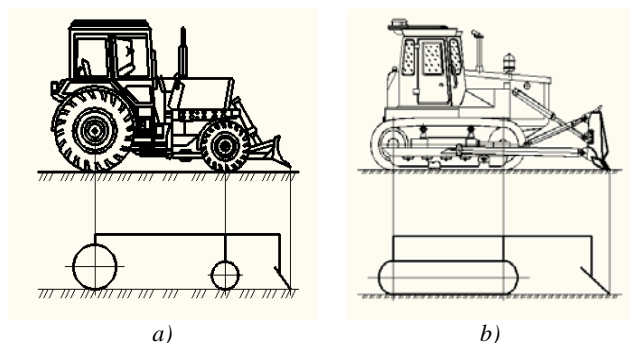

Figure 1. Scheme of bulldozer, a – with wheel bearing or b – with crawler bearing.

These bulldozers as machines and mechanisms, have in their kinematic schemes closed contours transition effects Yaw bearings - 1, located behind the working unit - 2 is transmitted through the frame of bulldozer 3 to working unit 2 (dump), and from the latter formed by them through movement to the support surface, Fig. 2.

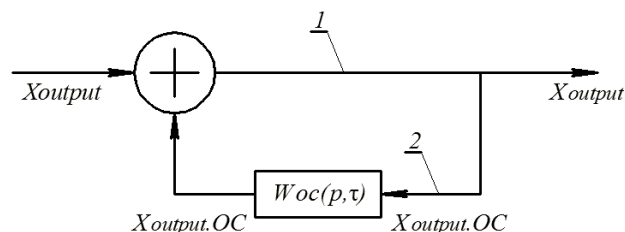

Figure 2. Scheme of direct 1 and feedback 2 of bulldozer.

There are direct 1 and feedback 2 connections in these specified machines. Feedback 2 of the bulldozer is delayed. We will assume the transition of effects in the bearing- frame-working unit chain as a direct connection, and from the working unit through the surface formed by them again to support – feedback. Deviations of bearings located behind the working unit are caused by a shift of the latter, but in relation to them are occurred with delay time, which depends on the distance from the working unit to bearing and travel speed of the machine. Of course, bulldozer bearings fluctuations are not literal repetition of blade vibrations, since not all operating conditions can be identified offset edge of the working unit and profile surface formed by it. Surface of bearings movement is not absolutely rigid, also like bearings, for example pneumatic-tire wheels, and, finally, by virtue of the geometry of the bearings themselves, which are of great structural diversity and non-ideal cams of irregularities of its profile movement.

It is necessary to enter certain simplifications. In this regard, it is assumed that the entire working period of machine movement the working unit stays on the treated layer of soil. The blade tip (of working unit) is acute. Profile of to be formed surface is either the trajectory of the blade edge (of working unit) or functionally connected with it. Surface motion bearings (wheels or crawlers) and created by a working unit, is tough, and machine bearings have a view of either rigid struts or elastic suspension (springs) with linear characteristics, perfectly gauging the surface profile of its movement. In accordance with widespread assumptions in the theory of transport machines and such assumptions are introduced for the possibility of developing a theory of fluctuations in the elastic (pneumatic) wheels [1,2,3].

Bulldozer models can be divided into two classes, the difference between them will be considered by the example of flat models, shown in Figure 3. In the first case we can neglect the deformations of bearings and surfaces of their movements and consider that bearings have rigid props, perfectly gauging rigid profiles of their movement, Fig.3a. In this case the position of the machine as a planar rigid body at any time is determined by the position of its two contact points B and C of bearings with surfaces (tracks) of its movement. Consequently, in this case, movement of the machine is studied purely in kinematic aspect as copying the points B and C of some profiles and transmission through deviations frame of these points on the edge of the working unit D. Bulldozer movement, particularly point D displacement vertically defined by movement of wheels or

crawlers according to created profile of the cutting edge D. In the case of the spatial model which has multiple bearings, moving along the surface formed by the working unit, the problem is complicated.

Bulldozer models shown in Fig. 3b and 3c have one or two elastic and deformable bearings, and therefore, to describe their movement it is necessary to model the relevant differential equations. The model shown in Fig.3a and others like this, can be called a kinematic or programmed movement system, and in Fig. 3b and 3v dynamic.

Two ways of tooling feedback can be mentioned by Fig. 3a and 3b compared to Fig. 3v. In the first two cases, we have rigid bearings, located behind the working unit, moving along the absolutely rigid surface formed by them. This surface, limiting the number of degrees of freedom of the machine, as a solid body, is a constraint and has all the properties relevant existing classification. It can be holonomic and nonholonomic (recently, for example, wheel type bearings), scleronomic and rheonomic, unilateral and bilateral. Along with this the movement of bearings surface C in Fig. 3a and 3b also has the property that is formed by the machine itself, its working unit in the movement process. The equation of this surface (or trajectory in the plane case) is not specified in advance and must be based on the analysis of the machine movement itself.

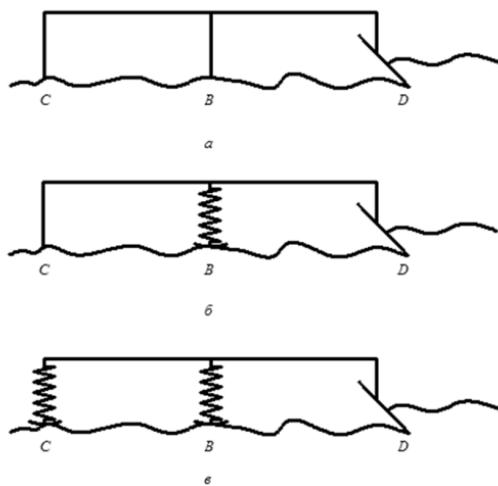

Figure 3. Bulldozer models

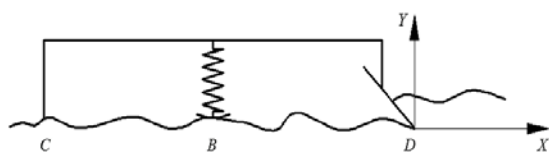

Figure 4. Forming the surface of bearings movement B and C.

Forming the surface of bearings movement occurs on segments, Fig. 4. In the start position of machine it is necessary to assume some surface between the bearing C and working unit D. We call this initial. Front bearing moves according to a predetermined surface. When moving of the machine bearings C and B move in the initial segment, and working unit D creates a new segment in this period of time, the form of which is determined by the state of the bulldozer movement. This equation must be calculated based on the observed laws of the machine movement, and in particular, its point D. In the following scheme for the plane scheme of the machine shown in Fig. 4, the trajectory of the point D is accepted as derivative trajectory of the points C and B movement. Thus, the trajectory of the points C and B consists of a number of segments consistently forming by the working unit while gauging bearings

C and B of each previous one. From the standpoint of mechanics the case shown in Figure 4 can be represented as the plane movement of a rigid body, some points C and B which are assigned along the trajectory of D.

For spatial machine schemes the working unit generates movement surface which is also formed by segments, and by the points C and B of bearings the location on these surfaces is assigned.

A characteristic feature of machines and mechanisms work with delayed feedback is their compliance with the automatic system, using the exception principle in the presence of feedback. In the automatic system, feedbacks are divided into rigid and flexible, positive and negative, major and local.

The feedback action study involves examining the changes of the controlled quantity (in this case the surface profile formed by a bulldozer) from appearing on the bulldozer shovel controlling the exposure. With the help of tachogenerator TG the output of the system is connected to its input. Thus, the feedback is a relationship, in which the information about the managed object state (surface profile of field) is transmitted from the output of the system to its entrance.

If the sign of the feedback action being supplied to the input of the system coincides with the sign of the reference action, so it is called positive. Otherwise, it is called negative feedback. In our case of the bulldozer work, the sign of the feedback action supplied to the input of the system coincides with the sign of the reference action, so it is called positive.

When transmitted feedback action depends only on the output quantity and does not depend on time, the constraint is considered rigid. Practically the rigid feedback acts as steady and transient conditions. Feedback that affects the operation of the system only in a transient condition is called flexible. Such constraints react to increment actions applied to their input. And those that respond to derivative actions are called differentiating, to integrals from actions are called integrating flexible feedbacks.

If feedback connects the output of the system with its input, it is called major. The remaining feedbacks are considered local. They serve to improve the adjustment features of individual elements or their groups, connecting the element or group of elements output to the corresponding input. They are also called correcting. Local constraints like a major can be flexible or rigid.

Transition process of the bulldozer will be made on the assumption that the model (Figure 5) is delay less, the deviation quantity of suspension points O1 and bearing are small compared with the length of the OS frame $OO_1 \leq CC_1$, velocity $v = \text{const}$ and bearing OO_1 has a rigid type of the prop.

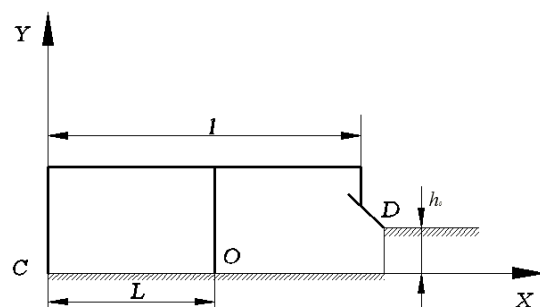

Figure 5. Tool model with feedback at a single push

Let us consider the model behavior (Figure 5) when the bearing O hits on a step with a deviation point D height of h_0 of the working unit on the quantity of h_1 as a single push. Because of the rotation model with respect to the bearing point C the working unit forms a first step. Changes in the depth of processing with height of ΔY_1

$$\Delta Y_1 = h_0 * k$$

where $k = \frac{l}{L}$.

When copying the first stage by bearing C the working unit forms the next step with height of ΔY_2 due to model rotation relative to point O_1 .

$$\Delta Y_2 = h_1(1 - k)$$

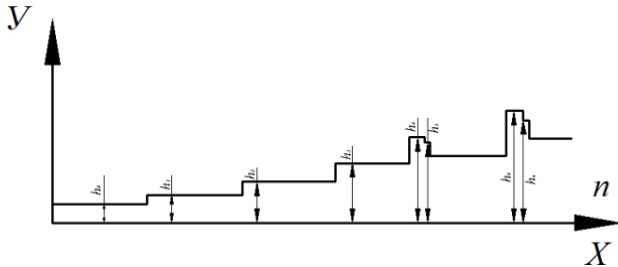

Figure 6. Transition processes

In the formation of n-the step the levelled ground change is equal to

$$Y_n = \Delta Y_1 + \Delta Y_2 + \Delta Y_3 + \Delta Y_4 + \dots + \Delta Y_n \quad (1)$$

The transition process calculated by equation (1) is shown in Figure 6.

Movement trajectory behavior (Figure 6) is described by a circular arc, parameters of which depend on the unit step height h_0 , the lengths l and L , k , etc. This dependence can be determined by examining r at different values of l and L , k .

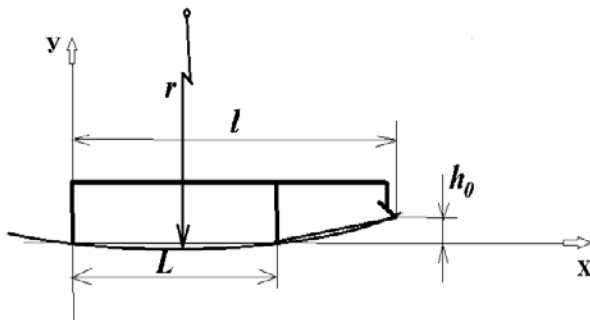

Figure 7. Scheme of determining the radius of circular arc curvature in the transition process of physical models of machines.

According to this experiment data the graph of $r = r(k)$ (Figure 9) can be made. The resulting curve gives you the opportunity to judge a function $r(k)$. However, the constant coefficients, which are included in this function, remain unknown. The method of least squares allows to determine them.

Radius r of the circular arc is defined by

$$r = \sqrt{\frac{h_0^2 L^2 + l^2(l^2 + L) + h_0^4 + 2l(h_0 - Ll + h_0L)}{4h_0^2}}$$

The analysis is valid for bearing in the form of a rigid prop and instant copying of vertical front steps. In real conditions various deviations are possible in the course of transition processes due to the influence of various factors.

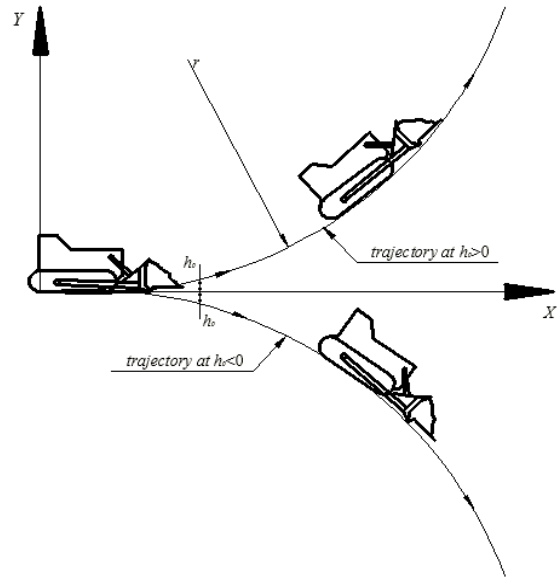

Figure 8. Scheme of the bulldozer working unit movement in the transition process from a unit step h_0

Figure 8 shows that when the unit step h_0 the theoretical transition tool is described by a circle radius r . Therefore, with little h_0 , through a small period of time, bulldozers are fully lowered or deepened. Therefore, operators very often steer the position of the working unit- bulldozer shovel.

We have determined the quantity of r (Figure 8) at different values of the coefficient k , from 1.05 to 1.25. Circle radius c range of the bulldozers transition process is 50-250m.

Results and discussion

The conducted studies of the operators (bulldozer drivers) work showed that in the process very often, sometimes every few seconds, they should adjust the shovels (working unit).

Transition processes of plane and spatial models machines and mechanisms with late feedback and with a coefficient greater than 1 under the influence of unit step of the bearing surface relief have been studied.

Research results have shown that bulldozers are machines and mechanisms with late feedback and with a coefficient greater than 1. For example, vertical deflection of bearings located behind the working unit is transmitted with a coefficient of more than one back through the frame to the working unit (shovel), causing expansion of the roughness formed by the machine as a radial arc.

To eliminate the expansion of roughness the operator intervenes in the course of the transmission process, by positive change in the position of shovels. Interference frequency is determined by work quality requirement, speed, primary roughness and surface properties of speed and bulldozer bearings.

The transition process at model coefficient $\kappa > 1$ from a single push - h_0 has the form of a circle with radius r .

Suggested theoretical research methods of machines and mechanisms models allow us to study their properties, parameters and modes.

Conclusion

The foundations of the theory of the machines and mechanisms with late feedback and with a coefficient greater than 1 study have been set, different from the existing approaches to the study of the problem. The application of this theory in calculations enables to prove optimal parameters and real machines and tools modes with late feedback.

We conducted laboratory research of transition processes of machines and mechanisms physical models with late feedback from a single push.

Primary cause of bulldozer operator's frequent intervention in controlling the shovel position is that transition process of tool increases in geometric progression at a slight push. This process can be described by a radial arc of radius r . In the absence of operator's intervention the bulldozer shovel fully lowers or deepens.

Bibliography

1. Rotenberg R. V. Car suspension. M., "Engineering", 1972
2. Smirnov G. A. The theory of wheeled vehicles movement. M., "Engineering", 1981
3. J.Wong. Theory of ground vehicles. M., «Engineering», 1982
4. Zhunisbekov P.Zh. Transition processes of tillage machines and tools with late feedback. // In book: Research papers of the KazAI – Alma-Ata: 1972. – p.29.
5. Ksendozov V.A. Introduction to Введение в machinery mechanics with late feedback. Moscow: Sputnik, 2005.
6. Zhunisbekov P.Zh.. Optimization of geometrical parameters of machines and tools with feedback // In book: Research papers of the KazAI – Alma-Ata: - 1977.