

# VEHICLE DYNAMOMETER USING FOR THE DIAGNOSING OF VEHICLE DRIVE TRAIN STATE

Ing. Tomáš Skrúcaný<sup>1</sup>, Ing. Branislav Šarkan, PhD., Ing. Ján Vrábek, PhD., Ing. Ľubomír Černický, PhD

University of Žilina, Department of Road and Urban Transport, Slovakia<sup>1,2,3</sup>

tomas.skrucany@fpedas.uniza.sk<sup>1</sup>

**Abstract:** The article is about the possibilities to diagnose the technical state of transfer mechanism of road motor vehicles. The diagnostic is done on a performance dynamometer, which measures the resistance of transfer mechanism during the coasting of rolling mass. The resistance makes itself felt like power losses by the movement of vehicle, which affects directly dynamical characteristics and fuel consumption. By the measurement we can quantify its value, what is the sign of the technical state of the mechanism.

**Keywords:** POWER LOSSES, OUTPUT POWER, DRIVE TRAIN, VEHICLE DYNAMOMETER

## 1. Introduction

During the vehicle moving, it is engaged by the various types of resistances. In addition to the external physical such as rolling resistance or drag it is also the vehicle's own resistance resulting from its structural arrangement and technical condition. With increasing value of these resistances, the engine output power is also increasing to overcome them. This fact increases the fuel consumption, shrinking the dynamic characteristics of the vehicle and reduces the transport of passenger comfort (noise, vibration). When it is not possible to influence the structural layout of the operational by the user, it is important to keep the various constituent parts of the vehicle not only capable of operation, but in the best condition. This will achieve the desired properties vehicle operation.

In this paper there we diagnose the state of the transmission using a cylindrical test laboratory in the laboratories of the Department of Road and Urban Transport at the University of Žilina.

## 2. Effectiveness of the drive train

Power and torque obtained from the crankshaft, must be transmitted to the wheels on the driving axle of the vehicle, which they passed on the road in the form of motive power, thanks to which the vehicle is moving. This is the role of the gear system, which provides two ways:

- power transmission at speeds unchanged
- power transmission speed changes

For physical law that power can not be changed during its transmission. Thus, the power input (to the whole shifting assembly or in parts) equals that of the output. As previously written, the influence of physical resistance can not be transferred without any loss of performance. So the output power is actually power at the reduced losses. This can be expressed in the form of efficiency gear system.

$$P_{out} = P_{in} - P_{loss} \quad ; \quad \eta_T = \frac{P_{out}}{P_{in}}$$

where	$P_{out}$	drive train output power [kW]
	$P_{in}$	drive train input power [kW]
	$\eta_T$	drive train efficiency [-]

Each part of the system transmits power to an intrinsic effect. The overall efficiency of the gear system is calculated as the product of the partial effect of the individual components.

$$\eta_T = \prod \eta_i$$

f.e.:  $\eta_T = \eta_{GB} \cdot \eta_{SF} \cdot \eta_D$

*GB* – gear box, *SF* – shafts, *D* – differential

The losses are mainly formed:

- friction in bearings and moving parts,
- mechanical transfers to a rigid kinematic linkage (teeth),
- the hydrodynamic transfers,
- splash of individual components in the oil filling.

The effectiveness results from the shifting assembly of these components, their design. The more parts, the greater the losses and lower efficiency. The same is true of the number of images of gear, shafts, joints, deposit. Thus, more complex shifting assembly, the lower its efficiency (the greater losses).

## 3. Vehicle dynamometer Maha LPS 2000

We use a performance dynamometer to determine the size of the loss power in the laboratories of the Department of Road and Urban Transport.

It consists of:

- Roller set,
- communication panel screen, keyboard and remote control,
- accessories (box interface for connecting sensors, engine cooling fan, fastening straps, suction device exhaust flue, printer).

Performance dynamometers can be supplied with different sets of rollers depending on the requirements of measurements being made. In general, can be measured trucks, cars and motorcycles.

Communication counter screen, keyboard and remote control used to control themselves from all power stations. Simply by moving the power station menu you can select the desired measurement.

The box interface is an inbuilt barometer and temperature sensor. Use the box interface can connect to the laboratory in a variety of external devices that are required for measurement.

### 3.1 The principle of the measurement

The dynamometer measures directly force at the periphery of the drive wheel of the car. It is transmitted by rolling the drive wheel on the measuring cylinder placed on the rotor, which is currently reading its speed. The cylinder transfers the power to the lever arm located on the stator. The strength of the arm picks up electromagnetic sensor. On the basis of the force measured on the arm we can determine the strength of the wheel. By the multiplying its speed (velocity) and force we can determine the wheel performance.

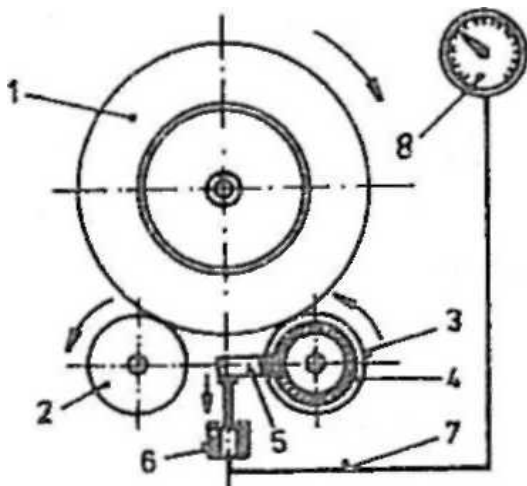


Fig. 1 Measuring principle of the dynamometer

1. driving wheel, 2. Rear support roller, 3. Frontal measuring roller and the stator of the break, 4. Stator, 5. Force arm, 6. Sensor, 7. Electric cable, 8. Display

### 4. Methodology of the power losses measurement

The procedure is continuous acceleration on the selected gear. The measurement is started after a speed 50km.h-1. At this point, it is necessary to fully depressing the accelerator and the following screen communications console. Once the maximum power operator turns off the clutch and the throttle is released. Now is the deceleration phase, in which the loss power is measured and calculated. After completion of measuring the output appears on the screen graphical representation of the engine according to the selected standard.

After the successful measurement are displayed on three line chart (Figure 6):

- Curve A shows the engine performance calculated in accordance with standards = the corrected power given the current pressure and temperature
- Curve B represents the measured power at the wheels
- Curve C represents the power dissipation
- Curve D represents the torque

Engine power (A) are summed to power on the wheels, (B) and power losses(C).

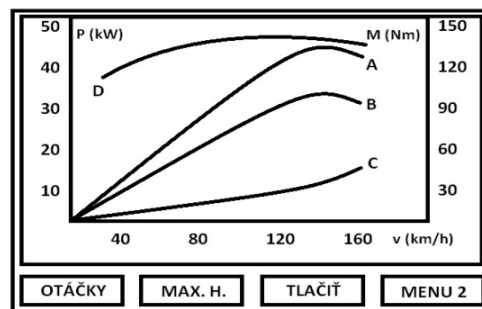


Fig. 2 Graphical evaluation of the results

Measured power loss is not only the loss of the transmission, but also rolling resistance, the driving wheel, rolling friction tires.

Even two identical vehicles may have a different value of power loss, for example due to different tires. But always, the rolling resistance is the largest resistance in the case of failure-free vehicle state. It depends mainly on:

1. wheel size
2. type of the tire
3. actual tire pressure
4. axle load

From these factor, the axle load affects the rolling resistance the most, thus heavier vehicles generally have greater losses than light vehicles. Even when comparing identical vehicles must meet their current weight and its distribution between the axles (persons and cargo on board).

A significant impact on rolling resistance has also the inflation pressure. Before the measurement, therefore, always be tire inflated to the pressure rewritten by the manufacturer and maintain for all measurements. This eliminates variations in measurements. The differences between tire pressures in each measurement can guide the diagnosis of some false failure of the transmission.

#### 4.1 Measurement abilities

In view of the above, it is possible to diagnose the condition of the vehicle as a comparative diagnosis of the same vehicle or two identical vehicles. We have the highest explanatory power measurement results if we have the opportunity to compare them with measurements carried out under fault conditions of a particular vehicle with the same tires and inflation pressure. The difference of the measured values is a fault condition. But there should be observed vehicles parameters affecting rolling resistance, so that their value must be the same in both vehicles.

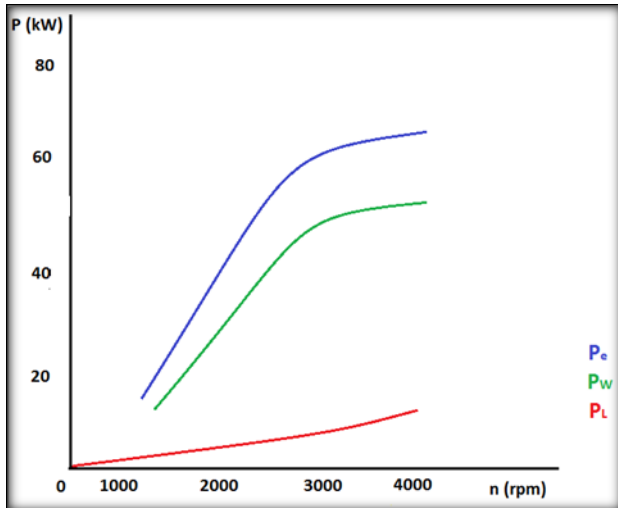
### 5. Measurement examples

The following measurements were carried out on the vehicle Citroen Berlingo 2.0 HDi. It is a vehicle with front-wheel drive.

Two fact should be evaluated in the diagnosis of graphical output:

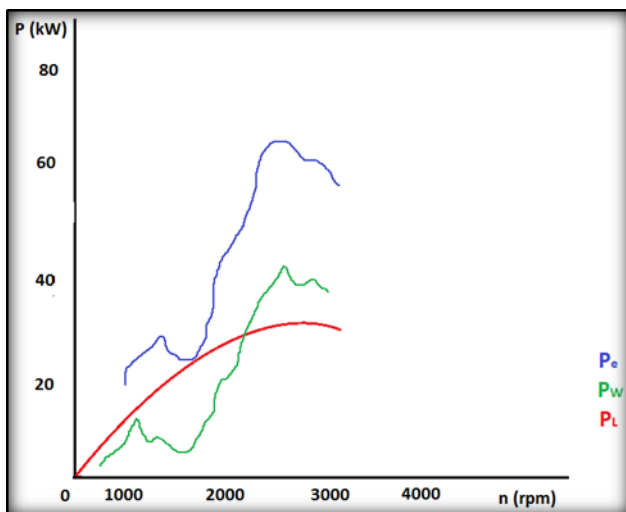
1. The value of the power loss (the rate to the output engine power)
2. The shape of the power loss curve

Not only value of the power loss points to a fault. Also, the shape of its values, the curve diagnosed condition. The shape of the curve at fault conditions shall be similar to the FIG. 4. Parabolic continuous growth is responsible for rolling resistance. If the curve will at some point fall or reduce the angle of the climb, there is a fault, also climb steep curve or purely linear progress.

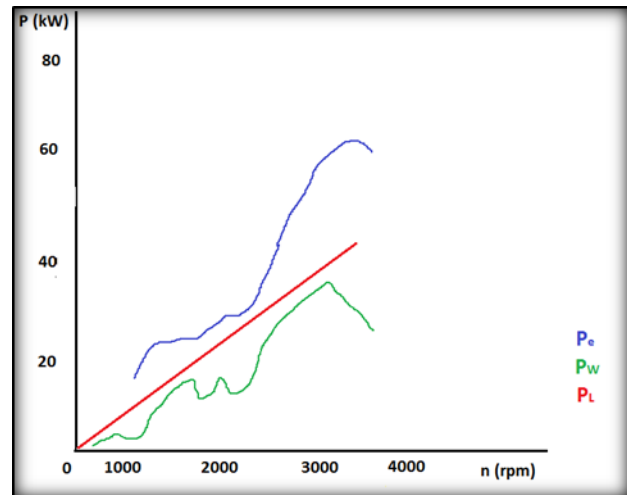


**Fig. 4** Power loss curve at failure-free state

$P_e$  – engine power,  $P_w$  – wheel power,  $P_L$  – power losses



**Fig. 5** Power loss at filre state (stuck brake pad)



**Fig. 6** Power loss at drive train failures

## 6. Conclusion

From the results it is observable that in the diagnosis by dynamometer it is not a detailed diagnostics which help to immediately identify a particular failure. Rather initial diagnosis, which provides insight into the overall state of the examined organs and thus induces a further fault-finding. In most cases, it is still necessary to use other methods, or look for the problem of removing individual parts to diagnose the failure. It is not able to compare the measured values of the power loss with standard table number. It is therefore necessary always to perform a comparative diagnosis of the same vehicle or two identical vehicles and in view of the deviation can be diagnosed whether or not a fault.

## 7. References

- [1] Liscak, Š. *Podvozky cestných vozidiel*. Žilina: EDIS, 2006. p.136. ISBN 80-8070-588-7
- [2] V. Rievaj, A. Kalasová, J. Rievaj., Fuel consumption and driving resistances. In: Archives of transport system telematics. - ISSN 1899-8208. - Vol. 5, iss. 2 (May 2012), s. 32-36.
- [3] Using of waste heat of internal combustion engines. In: Nauční izvestija [elektronický zdroj] : 22nd international scientific and technical conference trans & MOTAUTO '14 on transport, road-building, agricultural, hoisting & hauling and military technics and technologies : proceedings : 23.-24.06.2014 Varna, Bulgaria. - ISSN 1310-3946. - [Sofia]: Scientific-technical union of mechanical engineering, 2014. - Vol. 22, issue 7 (156), p. 62-64.
- [4] Instructions for operation of the vehicle dynamometer MAHA LPS 2000
- [5] SKRÚCANÝ, T. *Diagnostika stavu prevodového ústrojenstva pomocou valcovej skúšobne výkonu*. In: Technická diagnostika strojů a výrobních zařízení DIAGO 2014 [elektronický zdroj] : sborník konference. - ISSN 1210-311X. - Ostrava: VŠB - TU, 2014. - CD-ROM, p. 278-286.
- [6] GONGLAVES, G.A., FARIAS, T.L.: On-road measurements of emissions and fuel consumption of gasoline fuelled light duty vehicles. Instituto Superior Tecnico, Lisbon