

RESEARCH OF POSSIBILITY OF ELECTROMECHANICAL TURNING MECHANISM CREATING FOR TRACKED VEHICLE AS FIRST STEP TO HYBRID TRANSMISSION

Dr. Sci. (Tech), Professor, Volontsevich Dmitriy, Phd. Student Eng. Duong Sy Hiep,
Faculty transport machine building, National Technical University "Kharkov Polytechnic Institute", Ukraine.

Introduction

The need for a hybrid transmission for a vehicle has recently acquired great importance due to economic and environmental problems.

The possibility of a significant reduction in fuel consumption and emission of toxic gases when the engine is only achieved when using a hybrid transmission in which the excess energy during the engine and the alternator while driving coasting stored in batteries and used during acceleration or when a sharp increase in the resistance movement for various reasons. Such solutions are already used in many mass-produced vehicles, among other Toyota Prius and Honda Civic, as well as in the vehicles by "big three" of the USA.

Work on the use of hybrid transmissions for military vehicles have been conducted for a long time, but in Ukraine the development and application of hybrid transmissions for the army is taking place very slow.

Materials research.

Estimation of the required drive power electromechanical mechanism for turning on the example of a tracked vehicle multipurpose tractor MT-LB.

Consider a uniform rotation of the machine of mass m with a relatively large and constant speed v_C in the horizontal section area (Fig. 1). Assuming that the longitudinal component F_X of the centrifugal force F_C does not change the diagrams of normal loads on the track and does not cause changes in the steering force, and considering only the effect of shear force F_Y , we can calculate the displacement χ of the poles of turn O_1, O_2 and normal reactions of soil N_1 and N_2 . The indices 1 and 2, respectively, for lagging and outpacing boards.

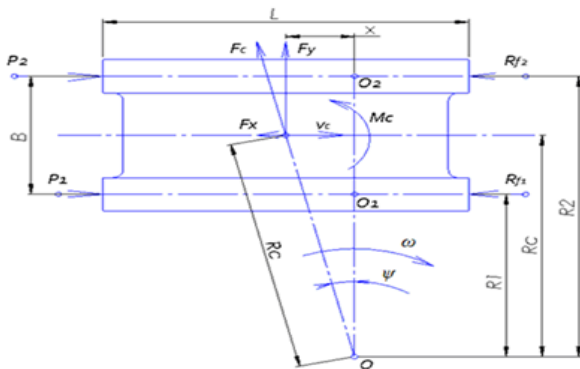
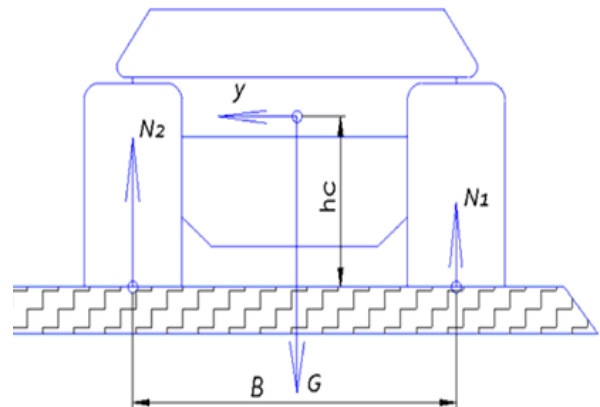

Fig. 1 – Calculation scheme



– Redistribution of loading on sides under action force F_c .

Centrifugal force and its transversal constituent are determined f

$$F_C = m\omega^2 R_C = \frac{G}{g} \left(\frac{v_C}{R_2 - \frac{B}{2}} \right)^2 R_C, \quad F_Y = F_C \cos \psi = F_C \frac{R_2 - \frac{B}{2}}{R_C} = \frac{G}{g} \cdot \frac{v_C^2}{R_2 - \frac{B}{2}}.$$

The shear force F_Y causes displacement of the poles of turn on a size χ , because it must be balanced against the transversal forces acting on the lower branches of caterpillars in the plane of the bearing surface

$$F_Y = 2\chi\mu \frac{G}{L} \Rightarrow \chi = \frac{F_Y L}{2\mu G}.$$

Then the longitudinal component of the centrifugal force will be determined as

$$F_X = F_Y \operatorname{tg} \psi = F_Y \frac{\chi}{R_2 - \frac{B}{2}} = \frac{F_Y^2 L}{2\mu G \left(R_2 - \frac{B}{2} \right)}.$$

If using S_1 and S_2 to identify lateral soil reaction per unit length of the bearing surface of a corresponding caterpillars, then

$$S_1 = \mu \frac{N_1}{L}, \quad S_2 = \mu \frac{N_2}{L} \Rightarrow S_1 + S_2 = \frac{\mu}{L} (N_1 + N_2).$$

The moment of resistance to turning is determined by the following expression

$$M_C = \int_0^{\frac{L+\chi}{2}} (S_1 + S_2) \chi dx + \int_0^{\frac{L-\chi}{2}} (S_1 + S_2) \chi dx = \mu \frac{G}{L} \left(\frac{L^2}{4} + \chi^2 \right) = \mu \frac{GL}{4} \left[1 + \left(\frac{2\chi}{L} \right)^2 \right].$$

From the equations of the moments relative to the poles of the turn we will get traction and braking respectively on the outpacing and the lagging caterpillars

$$P_2 = R_2 + \frac{M_C}{B} - \frac{F_Y \chi}{B} + \frac{F_X}{2}, \quad P_1 = R_1 - \frac{M_C}{B} + \frac{F_Y \chi}{B} + \frac{F_X}{2}.$$

Accordingly, the resistance force will be equal to $R_{f_2} = fN_2$ and $R_{f_1} = fN_1$.

The redistribution of loads between the caterpillars (Fig. 2) will be equal to $N_2 = \frac{G}{2} + F_Y \frac{h_C}{B}$ and $N_1 = \frac{G}{2} - F_Y \frac{h_C}{B}$.

Then, the expressions for the required thrust forces will have a look

$$P_2 = f \left(\frac{G}{2} + F_Y \frac{h_C}{B} \right) + \mu \frac{GL}{4B} \left[1 - \left(\frac{2\chi}{L} \right)^2 \right] + \frac{F_X}{2}; \quad P_1 = f \left(\frac{G}{2} - F_Y \frac{h_C}{B} \right) - \mu \frac{GL}{4B} \left[1 - \left(\frac{2\chi}{L} \right)^2 \right] + \frac{F_X}{2}.$$

With the increase of rate of movement the constituents F_X and F_Y increase, and tractive forces diminish, i.e. the turn of caterpillar machine is facilitated. Displacement of poles of turn increases at the same time. When it arrives at a size $\chi = \frac{L}{2}$ there is "skidding" of caterpillar machine and trajectory of motion distorted.

The maximum speed of a caterpillar on the condition of the complete skidding $v_C \geq \sqrt{\mu_{\max} g \left(R_2 - \frac{B}{2} \right)}$; on the condition of

the partial skidding $\sqrt{\mu g \left(R_2 - \frac{B}{2} \right)} \leq v_C < \sqrt{\mu_{\max} g \left(R_2 - \frac{B}{2} \right)}$; on the condition of motion without skidding

$$v_C < \sqrt{\mu g \left(R_2 - \frac{B}{2} \right)}. \text{ Here } \mu = \frac{\mu_{\max}}{a + \frac{(1-a)R_2}{B}}, \quad a=0.85.$$

The results and real fixed radiuses of turn for the different coefficients of resistance to rotation are brought around to the charts presented on fig. 3-5.

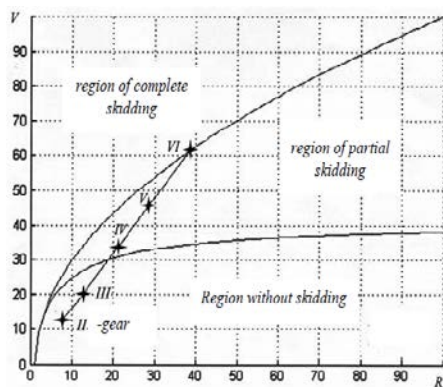
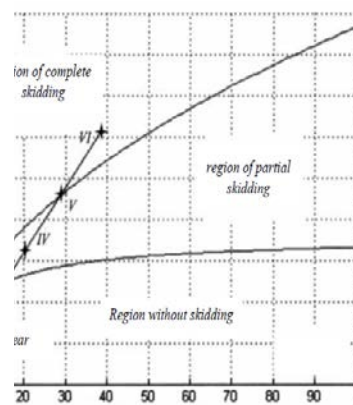

Fig. 3 – Dependence of speed on the radius of turn at the $\mu_{\max} = 0,8$



dependence of speed on the radius of turn at the $\mu_{\max} = 0,6$

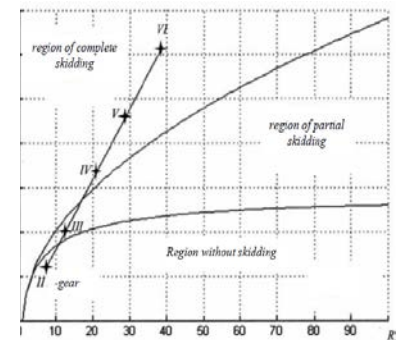

Fig. 5 – Dependence of speed on the radius of turn at the $\mu_{\max} = 0,4$

Table 1 – Calculation parameters of trackea venicie multipurpose tractor M1-LB in a turn

No transmission	$v_2, \text{ m/s}$	$v_1, \text{ m/s}$	$R_2, \text{ m}$	$v_C, \text{ m/s}$	$F_Y, \text{ N}$	$F_X, \text{ N}$	$\chi, \text{ m}$	μ	$P_2, \text{ N}$	$P_1, \text{ N}$	$N_2, \text{ kW}$	$N_1, \text{ kW}$	$N_{\text{nos}}, \text{ kW}$	$N_{\text{np}}, \text{ kW}$	$\Delta V, \text{ kW}$
I	1,11	0	2,50	0,56	2464	115	0,058	0,800	32990	-25028	36,62	0,00	36,62	8,71	27,91
II	3,33	2,22	7,50	2,78	12321	744	0,378	0,615	25702	-17110	85,59	-37,98	47,60	26,13	21,47
III	5,75	4,64	12,95	5,20	23066	1744	0,885	0,492	18562	-8970	106,73	-41,62	65,11	45,13	19,98
IV	9,47	8,36	21,33	8,92	39583	3917	1,987	0,376							
V	13	11,89	29,28	12,45	55256	6694	3,395	0,307							
VI	17,08	15,97	38,47	16,53	73371	10768	5,462	0,253							
R	2,86	1,75	6,44	2,31	10234	588	0,298	0,647	27091	-18655	77,48	-32,65	44,83	22,45	22,39

For determination of expenses of power we will be set by next basic data: $m = 10000$ kg; $B = 2,5$ m; $L = 3,7$ m; $f = 0,08$; $\mu_{\max} = 0,8$. Speeds and radiuses of turn, provided by the regular transmission of a tracked vehicle multipurpose tractor MT-LB in the mode of maximal power, are driven to the table.

Determination of minimum radiuses of turn on the condition of the complete skidding for all transmissions of slow row, and also the calculation of necessary twisting moments and angulators on managing elements we conduct on a next algorithm: radiuses of turn, corresponding to the border of beginning of skidding of machine for each of certain on a table speeds we find on a formula

$$v_C < \sqrt{\mu g \left(R_2^* - \frac{B}{2} \right)}. \text{ Where } \mu = \frac{\mu_{\max}}{a + \frac{(1-a)R_2^*}{B}}, a=0.85. \text{ Conducting a substitution and transformations, we will get}$$

$$v_C^2 = \frac{\mu_{\max}}{a + \frac{(1-a)R_2^*}{B}} g \left(R_2^* - \frac{B}{2} \right), \text{ from where } R_2^* = \frac{\mu_{\max} g \frac{B}{2} + a v_C^2}{\mu_{\max} g - \frac{(1-a)v_C^2}{B}}.$$

Further we find the radiuses of turn R_2^{**} , corresponding to beginning of the complete skidding of machine for each of certain on a previous step speeds (see a table.). We determine the angulator of turn of machine corps of relatively vertical axis ω_C and check it for exceeding $1,5 \text{ s}^{-1}$, that corresponds to the maximally possible horizontal accelerations for a crew. If necessary we increase a radius to the value at that speed $\omega_C = 1,5 \text{ s}^{-1}$. Taken on for further calculations values we add to the table.

Was counted the values of linear speeds of outpacing v_2 and lagging v_1 sides which added to the table.

The size of centrifugal force arising up at a turn with the calculated descriptions $F_Y = m \frac{v_C^2}{R_2 - B/2}$. Relative displacement of

poles of turn χ_0 under the action of force of inertia we find on a formula $\chi_0 = \frac{F_Y}{\mu mg}$. If the got values more unit, then we accept their

$\chi_0 = 1$ and we count the coefficient of resistance to the turn on a formula $\mu = \frac{F_Y}{mg}$. We find normal reactions under outpacing Q_2 and

lagging Q_1 sides.

The coefficient of moment of resistance to the turn we find from the condition of absence of central forces defiat even distribution of pressure on length of tracks $K = 1 + \chi_0^2$. Longitudinal constituent of inertia force $F_X = F_Y \frac{\chi_0 L}{2(R_2 - B/2)}$

Tractive forces on outpacing P_2 and lagging P_1 to the sides, necessary for realization of turn machines with the set speed and radius on the prospected soil make:

$$P_2 = fN_2 + \frac{\mu L}{4B} mgK - \frac{F_Y L}{2B} \chi_0 + \frac{F_X}{2}; \quad P_1 = -fN_1 + \frac{\mu L}{4B} mgK - \frac{F_Y L}{2B} \chi_0 - \frac{F_X}{2}.$$

Twisting moments on the sunny cog-wheels of resumptive planetary rows taking into account streamline of power on sides (fig. 6):

$$M_{C\Sigma 2} = \frac{M_{B\Pi 2}}{i_{\Sigma}^M \eta_{\Sigma}}, \text{ where } M_{B\Pi 2} = \frac{P_2 R_{BK}}{i_{B\Pi} \eta_{\text{гyc}2} \eta_{B\Pi}}; \quad M_{C\Sigma 1} = \frac{M_{B\Pi 1}}{i_{\Sigma}^M \eta_{\Sigma}}, \text{ where } M_{B\Pi 1} = \frac{P_1 R_{BK}}{i_{B\Pi} \eta_{\text{гyc}1} \eta_{B\Pi}} \text{ for the mode of traction}$$

from an engine and $M_{C\Sigma 1} = \frac{M_{B\Pi 1} \eta_{\Sigma}}{i_{\Sigma}^M}$, where $M_{B\Pi 1} = \frac{P_1 R_{BK} \eta_{\text{гyc}1} \eta_{B\Pi}}{i_{B\Pi}}$ for the mode of braking by a lagging side and recuperation

of power.

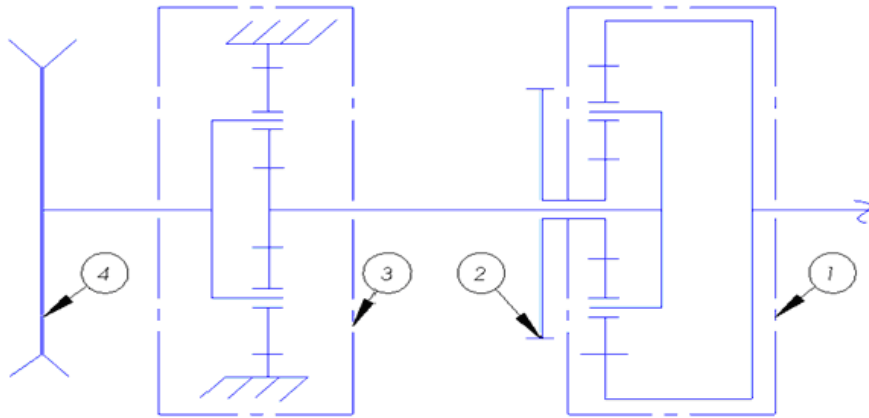

Fig. 6 – Kinematics chart of fragment of transmission
 1 – resumptive planetary row; 2 – gear-wheel of drive of turn mechanism; 3 – side reducing gear; 4 – driving-wheel

Here:

$$R_{BK} = 0,265 M - \text{radius of driving-wheel;}$$

$$i_{B\Pi} = 6 - \text{transmission relation of side reducing gear;}$$

$$i_{\Sigma}^M = 3,41 - \text{power transmission relation of resumptive planetary row in direction}$$

from a sunny cog-wheel to lever of planetary row; $\eta_{\Gammayc2} = 0,95 - 0,018|v_2|$

or $\eta_{\Gammayc1} = 0,95 - 0,018|v_1|$ – output-input ratio caterpillar mover accordingly

for outpacing and lagging sides; $\eta_{B\Pi} = 0,98$ – output-input ratio side transmission;

$\eta_{\Sigma} = 0,9$ – output-input ratio resumptive planetary row.

The angulars of corona gear-wheels of resumptive planetary rows we determine for all transmissions in the mode of rectilinear motion $\omega_{\text{ЭП}\Sigma} = \frac{v_C}{R_{BK}} i_{B\Pi} i_{\Sigma}^{K0}$, where $i_{\Sigma}^{K0} = 1,415$ – kinematics transmission relation of resumptive planetary row in direction from an epicycle to lever of planetary row at a shut-down sunny cog-wheel.

The angulars of sunny cog-wheels of resumptive planetary rows we determine for all transmissions in the mode of turn with before certain linear speeds on outpacing and lagging to the sides:

$$\omega_{B\Pi2} = \frac{v_2}{R_{BK}} i_{B\Pi} \quad ; \quad \omega_{B\Pi1} = \frac{v_1}{R_{BK}} i_{B\Pi} \quad , \quad \omega_{C\Sigma2} = -2,41\omega_{\text{ЭП}\Sigma} + 3,41\omega_{B\Pi2} \quad ;$$

$$\omega_{C\Sigma1} = -2,41\omega_{\text{ЭП}\Sigma} + 3,41\omega_{B\Pi1} .$$

Power on the sunny cog-wheels of resumptive planetary rows $N_{C\Sigma2} = \omega_{C\Sigma2} M_{C\Sigma2}$ and $N_{C\Sigma1} = \omega_{C\Sigma1} M_{C\Sigma1}$

Table 2 – Geometrical, kinematics and power descriptions of turn of a tracked vehicle multipurpose tractor MT-LB

№ transmission	$v_C, \text{ m/s}$	$R_2^*, \text{ m}$	$\omega_C^*, \text{ s}^{-1}$	$\omega_C, \text{ s}^{-1}$	$r_2, \text{ m}$	$v_2, \text{ m/s}$	$v_1, \text{ m/s}$	$F_T, \text{ N}$	μ	$\chi, \text{ m}$	$\%_0$	$F_x, \text{ N}$	$Q_2, \text{ N}$	$Q_1, \text{ N}$
R	-1,75	1,64	-4,48	-1,50	2,42	-3,63	0,13	26250	0,80	0,616	0,333	13853	59550	38550
II	2,22	1,88	3,54	1,50	2,73	4,10	0,35	33300	0,79	0,796	0,430	17906	62370	35730
III	4,64	3,99	1,69	1,50	4,34	6,52	2,77	69600	0,72	1,822	0,985	40998	76890	21210
IV	8,36	10,16	0,94	0,94	15,00	9,12	7,60	50829	0,52	1,85	1	6839	69382	28718
V	11,89	19,26	0,66	0,66	25,00	12,52	11,26	59525	0,61	1,85	1	4637	72860	25240
VI	15,97	33,75	0,49	0,49	50,00	16,38	15,56	52316	0,53	1,85	1	1985	69976	28124

Continuation of table

№ transmission	K	P_2, N	P_1, N	$\eta_{\text{твс2}}$	$\eta_{\text{твс1}}$	$M_{\text{ЭМ2}}, Nm$	$M_{\text{ЭМ1}}, Nm$	$M_{\text{СЭ2}}, Nm$	$M_{\text{СЭ1}}, Nm$	$\omega_{\text{СЭ2}}, S^{-1}$	$\omega_{\text{СЭ1}}, S^{-1}$	$N_{\text{СЭ2}}, kW$	$N_{\text{СЭ1}}, kW$
R	1,111	37642	-15941	0,885	0,948	1917	-758	574	-227	-144,8	144,8	-83,1	-32,8
II	1,185	37285	-11531	0,876	0,944	1918	-551	574	-165	144,8	-144,8	83,1	23,9
III	1,970	27432	21414	0,833	0,900	1485	1072	444	321	144,8	-144,8	64,3	-46,5
IV	2	8970	5717	0,786	0,813	514	317	154	95	58,7	-58,7	9,0	-5,6
V	2	8147	4338	0,725	0,747	507	262	152	78	48,3	-48,3	7,3	-3,8
VI	2	6591	3243	0,655	0,670	453	218	136	65	31,6	-31,6	4,3	-2,1

Choice of electric motors for the electromechanic of double-flux mechanism of turn of caterpillar machine

1. Engines of direct-current.

Basic advantage of these engines, that determined their general use on the stage of development of electric drives, is lightness of the smooth adjusting of speed in wide limits. Therefore with development of semiconductor industry and appearance of relatively inexpensive transformers of frequency the percent of their use diminishes constantly. Wherein it maybe direct-current re-engined by drives on the basis of asynchronous engines with a shortcircuited rotor. The basic lacks of engine of direct-current (not high reliability, complication of service and exploitation) are conditioned by the presence of collector knot.

2. Synchronous engines.

Basic advantage of synchronous engines is that they can work with the power-factor of $\cos\phi=1$. Their feature also is constancy of speed of rotation at the change of moment of loading on a billow. At all dignities of synchronous engine basic defects limiting their application are complication of construction, presence of causative agent, high price, starting complication.

3. Asynchronous engines.

On structural principle asynchronous engines are subdivided into engines with a shortcircuited and phase rotor. Thus the most used electric motors are asynchronous with a shortcircuited rotor. A so wideuse is conditioned by simplicity of their construction, service and exploitation, high reliability, relatively low cost. The lacks of such engines are a large starting current, relatively small starting moment, and for the smooth adjusting of speed the transformer of frequency is needed. For reduction of starting currents of asynchronous engine with a shortcircuited rotor the device of the smooth starting or transformer of frequency can be used.

From three considered types of electric motors evidently, that used synchronous electric motors as an electromechanic it is impossible without the additional box of transmission. The basic lacks of engine of direct-current is not high reliability, complication of service and exploitation, high cost, therefore using this type of electric motor as an electromechanic is not recommended. An asynchronous electric motor has three basic advantages: smooth adjusting of speed in wide limits by means of transformer of frequency; simplicity of construction, service and exploitation; high reliability and low cost. It was therefore made decision to choose an asynchronous electric motor as an electromechanic of turn mechanism.

Conclusions

1. The got calculation power necessary for realization of turn with the accepted parameters shows that for the second, one third of transmissions and transmission of back-draught applying an electromechanic without the complete processing of transmission and setting of powerful electric motors and generator is impossible.

2. Realization of turn on fourth, fifth and sixth transmissions due to the single motorized drive of mechanism of turn maybe without the cardinal processing of transmission of machine, because requires setting of one or two electric motors total power to 10-12 kW.

3. At an attempt on all transmissions to realize only the electromechanic of mechanisms of turn thrown away opportunity the use of mechanical drive on a low gear that must provide if necessary the protracted work of machine in heavy travelling terms.

4. In connection with the stated the combined drive of mechanisms of turn that would allow on more subzero transmissions to use a mechanical drive with the fixed radiuses of turn and on higher transmissions is offered is an electromechanic with the smooth adjusting of radius of turn. In addition, an offer technical solution will allow to use the electromechanic of mechanisms of turn for the brief increase of power in the modes of rectilinear motion due to the power accumulated in storage batteries, that will promote descriptions of mobility of machine substantially.