

Design of an Industry 4.0-Based, Vertically Angular Automated Line Separator

Tahsin Topbaşoğlu¹, Enes Bitigen¹⁻², Ali H. Nazik¹⁻², Onur Çimen¹, İ.Etem Saklakoğlu¹⁻²
 KANSAN R&D Center, Izmir, Türkiye¹
 Ege University, Department of Mechanical Engineering, Izmir, Türkiye²
 tahsintopbasoglu@kansanmak.com

Abstract: In this study, an original design was developed to address the issue of insufficient packaging speed, a key challenge in wet wipe production lines. A separator/distributor was developed that enables a single wet wipe machine to work with three packaging units during the transfer of products from the wet wipe preparation unit to the packaging process. The developed separator moves angularly on the vertical axis and can transfer products to conveyor groups leading to three different packaging lines. Additionally, a unique movable upper conveyor was designed to operate across a range of product heights, which applies pressure to the products during movement to prevent them from scattering. One of the primary design criteria for the conveyor is lightweight construction, and this was a key focus during development. To achieve angular motion, a servo-driven flywheel mechanism was designed. The machine is equipped with sensors for Industry 4.0 compatibility, ensuring communication between units. In case one of the packaging machines becomes inactive, the separator automatically redirects the product feeding process to the remaining packaging machines, ensuring uninterrupted production.

Keywords: WET WIPE, PACKAGING, INDUSTRY 4.0

1. Introduction

In the modern industrial environment, optimizing production lines for efficiency and speed is crucial. Wet wipe production, in particular, faces the challenge of balancing product quality with high-speed packaging processes. A key issue in wet wipe production is the limitation in packaging speed, which can lead to bottlenecks and inefficiencies.

Industry 4.0 has revolutionized manufacturing by introducing smart technologies, including the Internet of Things (IoT), sensors, and automated systems, which enable enhanced communication and coordination between machines. This paper presents an innovative solution to increase packaging efficiency in wet wipe production by designing a vertically angular automated line separator that integrates Industry 4.0 technologies.

2. Literature Review

The literature on manufacturing automation, particularly in production line optimization, emphasizes the need for efficient systems that enhance productivity and flexibility. Recent advancements have allowed for the development of automated separators and conveyors that help address the challenges posed by high-speed packaging, especially in the context of multi-line production environments where efficiency is paramount. This review focuses on automation in manufacturing, the role of vertically angular systems, Industry 4.0 integration, and recent packaging innovations, with the aim of establishing a basis for the proposed design of an Industry 4.0-compatible, vertically angular automated line separator.

2.1. Automation in Manufacturing and Packaging Lines

Manufacturing automation, a cornerstone of industrial development, has undergone several transformations, with each phase introducing technologies that reduce human intervention, streamline production, and decrease operational costs. Initially, automation focused on simple mechanized tasks, but advancements in robotics and control systems have enabled more complex operations, including real-time adjustments and multi-directional product flow. Flexible conveyor and distribution systems have become essential in modern manufacturing environments, allowing lines to adapt dynamically to changing production demands [1, 2].

Flexible conveyor systems have been identified as a solution to minimize downtime and optimize product flow. Studies reveal that traditional conveyor systems, while effective, often struggle in high-speed production environments, particularly when dealing with products of variable shapes and sizes. By integrating modular and adaptive conveyors, manufacturers can meet these demands while reducing production costs. Research on the use of robotic arms and other mechanical actuators shows that automation systems with

precise control and flexibility can effectively handle variable product dimensions, achieving reliable, repeatable separation and distribution in packaging lines. These findings support the development of systems capable of transferring products to multiple packaging units, addressing a common need in high-output industries such as consumer goods and pharmaceuticals.

2.2. Vertically Angular Systems in Manufacturing

The implementation of vertically angular motion within conveyor systems presents a significant opportunity for optimizing space usage and enhancing flexibility in product handling. Traditional conveyor setups, typically limited to horizontal movement, can occupy large areas of the factory floor and restrict the ability of a production line to handle varying product heights. By enabling angular movement along the vertical axis, manufacturers can design systems that utilize available space more effectively, particularly in facilities where space constraints are a concern.

The design of vertically angular conveyors, especially in compact environments, has been shown to reduce operational complexity and improve the flow of products through multi-line processing systems. This approach not only conserves space but also allows for more efficient utilization of resources by aligning product flow with specific line requirements, such as directing items to different packaging stations based on real-time line status. Although the vertical movement is well-documented in material handling applications, studies reveal a lack of comprehensive exploration into systems that combine vertical and angular motion, especially with industry-specific applications. This study aims to bridge this gap by integrating a servo-driven flywheel mechanism for controlled angular movement, which ensures precise product positioning and transfer across multiple lines.

2.3. Industry 4.0 Integration and Smart Manufacturing Systems

Industry 4.0 represents a paradigm shift in manufacturing, bringing smart technologies and digitalization to traditional processes. By incorporating IoT, machine learning, and real-time data analytics, Industry 4.0 enables the creation of intelligent production environments where machines communicate autonomously, adjusting operations based on sensor inputs. This real-time communication and adaptability are particularly valuable in automated packaging systems, as they enable production lines to respond instantly to fluctuations in demand or disruptions within individual units [3].

The integration of IoT technologies allows for continuous monitoring of machinery, which is essential in high-speed production environments where equipment failure can result in significant downtime. The use of real-time data not only facilitates predictive maintenance but also enables optimization algorithms to adjust production rates, manage inventory flow, and maintain

product quality. For example, real-time tracking of product movement and adaptive control can ensure seamless transitions between different sections of the production line, reducing product loss and minimizing human intervention [4].

Smart manufacturing technologies also enable efficient coordination across interconnected units, which is crucial for multi-line systems that must operate in unison to achieve optimal throughput. Predictive maintenance models powered by machine learning provide a framework for forecasting equipment failures, allowing operators to address issues before they result in production stoppages. By implementing these smart technologies, the proposed separator design aims to maintain uninterrupted product flow even if one of the packaging lines goes offline, maximizing productivity and minimizing waste.

2.4. Innovations in Packaging Systems

Packaging is a critical phase in production, particularly in high-speed environments where products must be handled with precision to prevent damage or misalignment. Modern packaging systems incorporate modular and flexible designs that allow manufacturers to adapt to changing product requirements quickly. Studies indicate that modularity in packaging equipment offers significant advantages in terms of scalability and customization, as operators can reconfigure lines to handle products of different sizes, shapes, or packaging formats without extensive retooling [5].

Automated distributors and separators designed to work in tandem with packaging machines have proven effective in enhancing line efficiency. By directing products to multiple packaging stations, these systems reduce the likelihood of bottlenecks and improve overall throughput. For industries requiring high-speed packaging, automated separators that facilitate smooth transitions between preparation and packaging stages are essential for maintaining product integrity and consistency.

Modular design is another area of focus, allowing packaging systems to adjust quickly to new product demands. Research into modular packaging line architecture has shown that reconfigurable systems can meet varying production needs with minimal downtime, which is especially valuable in fast-paced industries like consumer goods. The proposed design incorporates a movable upper conveyor to accommodate products of different heights, preventing product scattering and ensuring secure transfer to the packaging units. The lightweight construction of the conveyor also supports rapid, angular movement, providing a compact and ergonomic solution to meet production demands [6].

2.5. Gaps in Current Research

Despite significant advancements in automation and Industry 4.0 technologies, there is still limited research on integrating vertically angular motion with Industry 4.0-enabled packaging systems. Most studies focus on horizontal automation systems or isolated technology implementations, without considering integrated solutions that combine angular motion and smart manufacturing capabilities. This study addresses this gap by developing a vertically angular separator that leverages smart manufacturing systems for seamless communication, real-time monitoring, and automated adjustments [7].

The proposed design aims to create an efficient, adaptable separator capable of directing products to multiple lines based on real-time operational conditions. By combining vertically angular motion with IoT-enabled monitoring, the system promises to increase productivity and flexibility in packaging lines, meeting the evolving demands of high-output industries. This novel approach to automation, which prioritizes space efficiency, real-time adaptability, and minimized downtime, represents a new direction for research in automated packaging technology.

3. Design and Methodology

The goal of this study was to address the demand for an efficient product transfer system in wet wipe production lines, where products need to be transferred from a single production machine to three separate packaging machines. The challenge lies in meeting a high throughput requirement—up to 300 packages per minute—while ensuring each packaging machine can handle a maximum of 100 packages per minute. To meet these demands, a vertical angular automated separator was designed, with a focus on ease of adjustment, maintenance, ergonomics, space efficiency, and the ability to perform product transfer via angular motion on the vertical axis.

3.1. Separator Unit Design

The separator unit was designed to move angularly on the vertical axis, allowing it to transfer products to conveyor groups leading to three different packaging lines. The angular motion is crucial as it enables the system to handle multiple packaging lines without requiring excessive floor space, thereby improving the overall factory layout. This design also makes it adaptable to varying production needs, especially in high-speed environments where flexibility is essential [8].

The key innovation of this design is the incorporation of a movable upper conveyor that can function across a wide range of product heights. This feature allows the separator to handle products of varying dimensions without disrupting the product flow. The upper conveyor plays an essential role in ensuring that the products are maintained in a stable position during the transfer process. By applying light pressure as the product moves across the conveyor, the risk of scattering is minimized, ensuring smooth and efficient transfer to the packaging machines.

3.2. Lightweight Conveyor Design and Servo-Driven Flywheel Mechanism

The design of the conveyor system is centered on minimizing weight without compromising performance. The lighter construction of the conveyor enables faster movement, reducing wear and tear, and ensuring the longevity of the system. Additionally, this lightweight design facilitates easier adjustments and maintenance, providing the operator with a more ergonomic system for day-to-day operations.

To achieve the angular motion of the separator, a servo-driven flywheel mechanism was developed. This mechanism is designed to allow for precise angular movement while maintaining stability and reliability at high speeds. The servo drive ensures that the separator can adjust its angle quickly and efficiently, making it adaptable to various packaging line configurations. This system is crucial for achieving the required speed of 300 packages per minute while also handling the product transfer to multiple packaging lines.

3.3. Industry 4.0 Integration and System Automation

The separator unit is equipped with sensors and communication interfaces that integrate with the overall production line, ensuring compatibility with Industry 4.0 standards. This allows for real-time data exchange between the separator and the packaging machines, optimizing the efficiency of the system.

One of the key features of the design is its ability to maintain uninterrupted production. In the event that one of the packaging machines becomes inactive due to maintenance or malfunction, the separator automatically redirects the product flow to the remaining active packaging lines. This automatic redirection ensures continuous production without the need for manual intervention, thus reducing downtime and enhancing the overall efficiency of the manufacturing process.

3.4. Ergonomics and Maintenance Considerations

In addition to the technical functionality, the design emphasizes ergonomics and ease of maintenance. The system was built with user-friendly interfaces for quick adjustments and straightforward maintenance procedures. The lightweight design of the conveyors, along with their modular construction, allows for easy access to parts that require routine maintenance, reducing downtime and labor costs. The compact nature of the system also ensures that it occupies minimal space, making it ideal for factories with limited floor space.

The vertical angular movement of the separator further enhances the system's ergonomics, as it minimizes the need for large horizontal conveyors that could otherwise require more space and labor for adjustments. The angular motion system is easy to configure, and operators can quickly adapt it to meet different production requirements, making it highly versatile for various product types and packaging configurations.

The designed separator is shown in Figure 1a and the manufactured separator is shown in Figure 1b. In figure 2a the detail of design and figure 2b. detail of the manufactured separator is shown in front view. Rear view is shown Figure 3a and fig 3b.

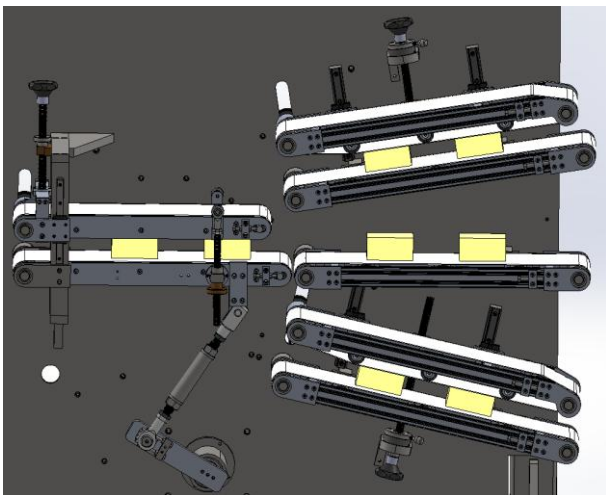

1a.



1b.

Figure 1a the designed and Figure 1b. the manufactured separator in front view

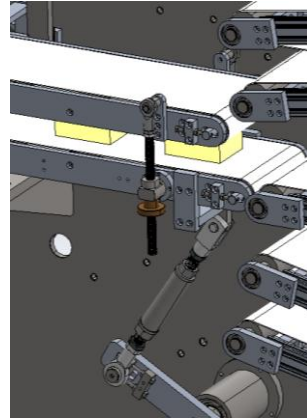

2a.



2b.

Figure 2a the detail of design and Figure 2b. detail of the manufactured separator in front view

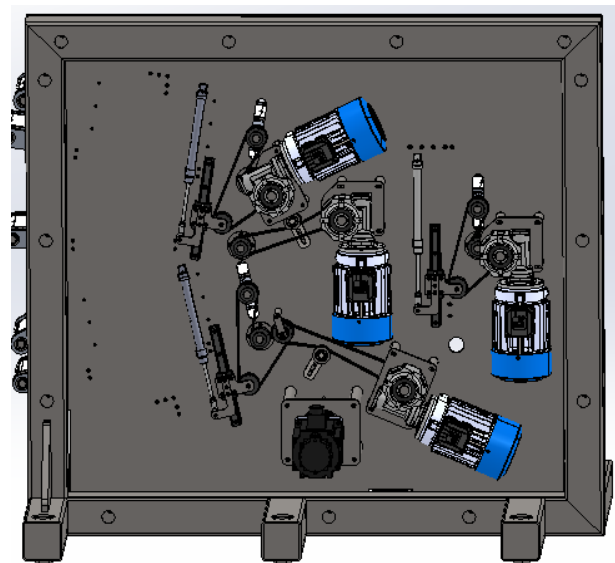

3a.



3b.

Figure 3a-b. Rear view of designed and manufactured separator

4. Results and Discussion

The vertical angular separator was tested in a real-world wet wipe production environment to evaluate its performance in handling high-speed product transfer to multiple packaging lines. The results confirmed the separator's ability to efficiently direct products from a single production line to three separate packaging lines, each capable of handling up to 100 packages per minute. This setup allowed for a sustained throughput of 300 packages per minute, meeting the target production speed and ensuring a balanced distribution of products across the three lines.

The servo-driven flywheel mechanism proved crucial for achieving precise control over the separator's angular motion. This mechanism allowed the separator to quickly adjust to shifts in production flow and align with each of the packaging lines without delays. The lightweight conveyor design contributed to the system's ability to operate smoothly at high speeds, effectively reducing mechanical stress and wear over prolonged periods of use. By minimizing the stress on mechanical components, the design also helped extend the lifespan of the separator and reduced maintenance needs.

Integration of Industry 4.0 features was particularly advantageous. Through real-time monitoring and feedback from embedded sensors, the separator could automatically reroute product flow if one of the packaging machines went offline. This function minimized potential downtime, maintaining continuous production—a critical feature in high-output manufacturing lines where any stoppage can result in significant productivity losses.

Furthermore, a patent application has been filed for the developed system, reflecting its innovative contributions to automated packaging line technology and the novel approach to integrating vertical angular motion with Industry 4.0 capabilities. This patent application not only highlights the uniqueness of the separator's design but also establishes a basis for future developments and potential commercialization in automated production and packaging systems.

5. Conclusion

This study presents a novel design for a vertically angular automated line separator that addresses the challenges of transferring products between multiple packaging machines in a high-speed wet wipe production line. The design successfully integrates Industry 4.0 technologies to ensure seamless communication between production units and minimize downtime. With its lightweight construction, ergonomic design, and adaptability to varying product heights, the separator system provides a highly efficient and flexible solution for modern manufacturing challenges.

Further research could explore the integration of additional smart technologies, such as AI-based predictive maintenance and advanced data analytics, to further enhance system performance and efficiency.

6. Acknowledgments

This study was conducted at the KANSAN R&D Center, with the collaboration of the Department of Mechanical Engineering at Ege University. We extend our gratitude to all involved team members and institutions for their invaluable support and contributions to the success of this project.

7. References

1. S. Tripathi, S. Shukla, S. Attrey, A. Agrawal, V. S. Bhadoria, "Smart Industrial Packaging and Sorting System," in: P. K. Kapur, O. Singh, S. K. Khatri, A. K. Verma (eds.), *Strategic System Assurance and Business Analytics. Asset Analytics*, Springer, Singapore, (2020). https://doi.org/10.1007/978-981-15-3647-2_18
2. M. Huang, J. Wu, Y. Tang, L. Shi, "Optimal Design of a Conveyor-Based Automatic Sorting System," 2020 IEEE 16th International Conference on Control & Automation (ICCA), Singapore, (2020), pp. 1124–1129. doi: 10.1109/ICCA51439.2020.9264520
3. J. H. Lau, "Recent Advances and Trends in Advanced Packaging," *IEEE Transactions on Components, Packaging and Manufacturing Technology*, vol. 12, no. 2, pp. 228–252, Feb. (2022). doi: 10.1109/TCPMT.2022.3144461
4. C. Liu, J. Fang, P. Yu, "Automatic Packaging System Based on Machine Vision," in: F. Sun, A. Cangelosi, J. Zhang, Y. Yu, H. Liu, B. Fang (eds.), *Cognitive Systems and Information Processing. ICCSIP 2022, Communications in Computer and Information Science*, vol 1787, Springer, Singapore, (2023), https://doi.org/10.1007/978-981-99-0617-8_16
5. L. Bhanwrela, J. Managre, N. Purohit, N. Gupta, "To Integrate and Optimize the Use of Programmable Logic Controller in Development of Horizontal Flow Wrap Packaging Machinery for Industry Needs," *Electrical and Electronics Engineering, ATC-Factory Automation Lab-MEI, Shri Vaishnav Institute of Technology and Science, Shri Vaishnav Vidyapeeth Vishwavidyalaya, Indore, India* (2024).
6. S. Haque et al., "Automatic Product Sorting and Packaging System," 2023 15th International Conference on Intelligent Human-Machine Systems and Cybernetics (IHMSC), Hangzhou, China, (2023), pp. 163–167. doi: 10.1109/IHMSC58761.2023.00046
7. L. Xiao, B. Qu, E. Shi, "Design of Automatic Packing System in Workshop Based on Programmable Logic Controller (PLC)," 2021 4th International Conference on Information Systems and Computer Aided Education (ICISCAE), (2021), pp. 2268–2272. <https://doi.org/10.1145/3482632.3484142>
8. F. Jordan, P. Schleuniger, "Detection and Synchronisation of Moving Packaging Units on a Conveyor Belt Using a Synchronised Portal," *University of Applied Sciences and Arts Northwestern Switzerland (FHNW), Windisch, Switzerland* (2021).